



STANDARD

SCOPE OF WORK AND TECHNICAL SPECIFICATION

GREEN HYDROGEN FUELING STATION

SEPTEMBER 2024



MESSAGE FROM CMD, NTPC LIMITED



Green Hydrogen plays a vital role, and it is part of a comprehensive energy portfolio that can ensure energy security, resiliency, economic value and environmental benefits for diverse applications across multiple sectors.

The present report comprehensively details the standard scope of works and technical specification for establishing Green Hydrogen Mobility Project. This report showcases our commitment and dedication for pushing the boundaries of Green Hydrogen. We are confident the information in this report would help in setting up of green hydrogen filling station across the country in an exponential manner.

As we continue to explore new frontiers in Green Hydrogen technologies, we remain committed to our mission of providing reliable and affordable power. We believe that our works will have a profound impact on Green Hydrogen Domain by mitigating the climate change and supporting of our national commitments.

I hope this report provides valuable insights and information for the Owner, EPC agency and manufactures alike.

Gurdeep Singh
CMD, NTPC Limited

MESSAGE FROM DIRECTOR (PROJECTS), NTPC LIMITED



The content of this report came from the experience of NTPC Team in setting up of two Green Hydrogen Mobility Project at Leh (Ladakh) and Greater Noida (U.P.) respectively. Leh project entails operating intra-city FCEVs with daytime generation of 80 kg/day whereas Greater Noida project envisaged of operating long haul inter-city FCEVs with three times more capacity than the Leh project.

While our NTPC RE Team diligently working on the above two projects, contribution of MoP, MNRE, UT of Ladakh Administration can never be over emphasized.

While this is a nascent area, generous support from esteemed organisations like PESO and ARAI helped us to develop our capability in setting up of hydrogen filling station.

This report provides key deciding information to the owner, inputs for various document preparations, technical and statutory requirements for establishing the Green Hydrogen Mobility Project.

I would like to acknowledge the exceptional work of our hydrogen team, whose dedication have made these accomplishments possible. Their approach and rigorous methodology have contributed significantly to NTPC's reputation as a leader in sustainable energy major.

K. Shanmugha Sundaram

Director (Projects), NTPC Limited



MESSAGE FROM EXECUTIVE DIRECTOR (RE), NTPC LIMITED

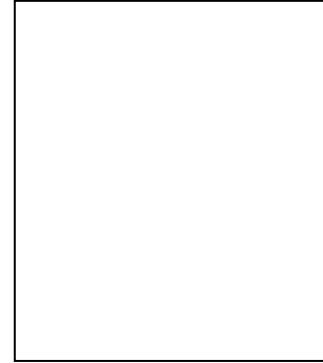

This report is a live document which provides details required for setting up of Green Hydrogen Mobility Project. The input for developing this report came from experience gained while the project Leh and Greater Noida were conceived and constructed.

We are confident that this report would be much valued and become a benchmark knowledge source. As NTPC would gain more experience and insights, this report will be updated in times to come. An updated version can be located in NGEL website (www.ngel.in).

Similar to this project, NTPC has already commissioned India's first Green Hydrogen Blending at Surat, Gujarat and working on various green hydrogen initiatives like hydrogen-locomotive, microgrid and green chemicals like ammonia, methanol, SAF etc.,

The inputs, technical details and references provided in this report will also be relevant for setting up of electrolyser, compressor and storage cylinders etc., for other green hydrogen application projects.

We are confident that with our collective efforts, NTPC will continue to lead the way in providing sustainable and reliable energy solutions for the nation.

Rajiv Gupta

Executive Director (RE), NTPC Limited

ACKNOWLEDGEMENT

This document is prepared with the encouragement and guidance from NTPC Management. We are thankful for the unique opportunity to work on two flagship Green Hydrogen Mobility Projects at Leh and Greater Noida respectively.

The upcoming Green Hydrogen Mobility Project at Leh is the World highest altitude Hydrogen fuelling station operating at 3500m with sub-zero temperatures for more than six months in a year, having in-site solar power generation plant. The project at Greater Noida is intended for supporting the operation of five hydrogen fuel cell buses for a long-haul distance of 600 km/day/bus.

We deeply appreciate timely support from UT of Ladakh Administration and Power Development Department extended from time to time and project is in the verge of completion.

We are also thankful all the stakeholders (EPC, OEMs, FCEV manufactures) for providing inputs in preparing this report.

Team Green Hydrogen



OBJECTIVE OF THIS DOCUMENT

1. This document provides information for setting up of Green Hydrogen Mobility Project. It covers required standards to be followed, inputs like footprint, water, electricity, scope of work, technical specifications, safety studies to be conducted etc.,
2. Typically, the facility is developed by an Owner by investing required fund, providing guidance and various inputs. Owner will get the engineering, procurement and construction works done through a selected EPC agency. The same agency will establish the intended project as mentioned by the Owner. Manufacturer(s) shall design, manufacture, test and supply the product to EPC agency for the installation and commissioning of the system.
3. This document provides information to following identified stakeholders.
 - ❖ Owner:
 - Requirements of footprint, water and power for establishing the green hydrogen mobility project.
 - Describes various statutory requirements and inputs to be provided to EPC.
 - Input required for preparation for the cost estimates and tender documents.
 - Support in reducing in discrepancy between EPC and Owner during the detailed engineering and project execution.
 - Provides guidance for developing conceptual and engineering capabilities.
 - ❖ EPC:
 - Equip themselves with know-how to set up the hydrogen mobility project
 - Technical requirements for system and sub-systems
 - Statutory requirements and Approval from local authorities.
 - Manpower requirement, skill requirement and infrastructure developments.
 - Establishing the supply chain requirements and sub-vendor development.
 - ❖ Manufacturers:
 - Standardise the product which suits for its requirements.
 - Establishing required infrastructure to design, manufacture, testing and commissioning of the product.
 - Supply the product which comply with all the standards and statutory requirements.

CONTENTS

ABBREVIATIONS	9
STRUCTURE OF THE CHAPTERS	12
A. GUIDANCE TO OWNER	14
1. Deciding factors for Hydrogen Fuelling Station.....	14
2. Layout and Clearance requirements.....	15
3. Project Management and Lead Time	16
4. Cost Estimate	18
B. PROJECT INFORMATION	19
1. Introduction	19
2. Location	19
3. Climatological Data	19
4. Near vicinity building and infrastructure	20
C. SCOPE OF WORK	21
1. Intent of Specification	21
2. Design Requirements.....	21
3. Brief Scope of Work.....	22
4. Detailed Scope of Work	22
D. TECHNICAL SPECIFICATIONS	25
1. Brief Input and Output of the System	25
2. Brief requirements of the System	25
3. Detail System Requirements	29
3.1 Electrical.....	29
3.2 Mechanical.....	36
3.3 Instrumentation.....	40
3.4 Integrated Control System (ICS).....	44
3.5 Safety Systems and Studies.....	47
3.6 Civil and Architectural Works	50
E. DOCUMENTATION	52
F. O&M CONTRACT	53



ANNEXURES	54
Annexure-I: Water Quality Parameters	55
Annexure-II: Basic Electrical Scheme	56
Annexure-III: Broad Layout of Office cum Switchgear Room.....	57
Annexure-IV: Building Materials.....	58
Annexure-V: Topographical survey and soil/geotechnical investigation.....	59
Annexure-VI: Minimum Requirement of ICS System	60
ADDITIONAL INFORMATION	65
Additional Information-I: List of Standards	66
Additional Information-II: Trial operation and Performance Guarantee (PG) test.....	69
Additional Information-III: Special Terms and Conditions	71
Additional Information-IV: Sub QR and Provenness Criteria.....	73
Additional Information-V: Layout of the Project	74



ABBREVIATIONS

AC	Alternating Current
ACB	Air blast Circuit Breaker
ANSI	American National Standards Institute
API	American Petroleum Institute
ASME	American Society of Mechanical Engineers
ATEX	ATmosphère Explosible
ATS	Automatic Transfer Switch
BASEEFA	British Approval Service for Electrical Equipment in Flammable Atmospheres
BESS	Battery Energy Storage System
BMS	Battery Management System
BPV	Boiler Pressure Vessel
BS	British Standard
CBCT	Core Balancing Current Transformer
CCoE	Chief Controller of Explosives, PESO
CCTV	Closed Circuit Television
CEA	Central Electricity Authority
CENELEC	European Committee for Electrotechnical Standardization
CGA	Compressed Gas Association
CIMFR	Central Institute of Mining and Fuel Research
CPWD	Central Public Works Department
CSIR	Council of Scientific and Industrial Research
DC	Direct Current
DCP	Dry Chemical Powder
DIN	Deutsches Institut für Normung
DM Water	Demineralised Water
DMP	Disaster Management Plan
DMR	Double Modular Redundancy
EC	European Regulation
ECBC	Energy Conservation Building Code
ELCB	Earth Leakage Circuit Breakers
ELR	Earth Leakage Relay
EMC	Electromagnetic compatibility
EMERA	Escape Muster and Emergency Response Analysis
EMS	Electrical Management System
EN	European Norms
EPC	Engineering, Procurement, and Construction
ERTL	Electronics Regional Test Laboratory
ESD	Emergency Shutdown Device
EWS	Engineering Workstation
FBT	Fast bus transfer
FCEV	Fuel Cell Electric Vehicle
FFL	Finished Floor Level

FM	Factory Mutual Laboratories
FRLS	Fire Retardant and Low Smoke
GC	Gas Chromatograph
GUI	Graphical User Interface
H₂	Hydrogen
HAC	Hazardous area classification
HART	Highway Addressable Remote Transducer
HAZOP	Hazard and Operability
HIRA	Hazard Identification and Risk Assessment
HMI	Human machine interface
HT	High Tension
HTFS	Heat transfer fluids
HTRI	Heat Transfer Research, Inc
HVAC	Heating Ventilation and Air Conditioning
ICS	Integrated Control System
ICS	Integrated Control System
IEC	International Electrotechnical Commission
IECEx	International Electrotechnical Commission Explosive
IEEE	Institute of Electrical and Electronics Engineers
IMD	Indian Meteorological Department
IP	Ingress Protection
IS	Indian Standard
IS	Intrinsically Safe
ISA	International Society of Automation
ISO	International Organisation for Standards
LAN	Local Area Network
LCD	Liquid Crystal Display
LCIE	Laboratoire Central Industries Electriques
LED	Light Emitting Diode
LEL	Lower Explosive Limits
LOTO	Lock Out Tag Out
LT	Low Tension
MCB	Miniature Circuits Breakers
MCC	Motor Control Cubicle
MCCB	Moulded Case Circuit Breaker
MSDS	Material Safety Data Sheet
NBC	National Building Code
NDE	Non-Destructive Examination
NDT	Non-Destructive Testing
NFPA	National Fire Protection Association
O&M	Operation and Maintenance
OEM	Original Equipment Manufacturer
OISD	Oil Industry Standards Directorate
OPC	Optical portable communication
OPC	Ordinary Portland Cement
OPEX	Operational Expenditure

OWS	Operator Workstation
PAM	Personnel Area Monitor
PBG	Performance Bank Guarantee
PCC	Point of common coupling
PEB	Pre-Engineered Building
PESO	Petroleum and Explosive Safety Organisation
PG	Performance Guarantee
PLC	Programmable Logic Controller
PSA	Pressure Swing Absorption
PSU	Power Supply Unit
PTR	Performance Track Record
PVT	Production Validation Test
PWHT	Post Weld Heat Treatment
QMR	Quadruple Modular Redundancy
QRA	Quantitative Risk Assessment
RE	Renewable Energy
RMU	Ring Main Unit
RO	Reverse Osmosis
RS	Raman Spectrometry
RTC	Round the clock
SCADA	Supervisory Control And Data Acquisition
SCVS	Servo Controlled Voltage Stabilizer
SIL	Safety Integrity Level
SIS	Safety Instrumented System
SMART	Specific, Measurable, Achievable, Relevant, Time-bound
SMPV	Static and Mobile Pressure Vessel
SPD	Surge Protection Device
SS	Stainless Steel
SSD	Solid State Drive
TCP/IP	Transmission Control Protocol/Internet Protocol
TEMA	Tubular Exchanger Manufacturers Association
TMR	Triple Modular Redundancy
TMS	Thermal Management System
UL	Underwriter Laboratory
UPS	Un-interrupted Power Supply
VFD	Variable Frequency Drive
WL	Water Liters
XLPE	Cross Linked Polyethylene
ZLD	Zero Liquid Discharge

STRUCTURE OF THE CHAPTERS

CHAPTER A – GUIDANCE TO OWNER

- It outlines the broad design elements and factors contributing to project setup time and total cost of the green hydrogen filling station.
- A tentative layout has been presented to sensitize about relative placement of equipment's as per present statutory guidelines.

CHAPTER C – PROJECT INFORMATION

- The format provided in this chapter, gives guidance to the owner to specify the details of the project intent and its location details. EPC will use this data for detail engineering, planning and project execution.

CHAPTER D – SCOPE OF WORK

- In this chapter, brief and detailed scope of works of the project is suggested. The intent is to suggest the quantum of works involved so as to anticipate the cost implication and time requirement for establishing the project.
- EPC also understand the broad requirement and make sufficient manpower for engineering, project management and execution, supply chain management, O&M etc.,

CHAPTER E – TECHNICAL SPECIFICATIONS

- In this chapter, owner is guided to provide the details of input available and requirements of various equipment's and system for the project.
- Exhaustive guidance is provided for electrical, mechanical, instrumentation, control system, safety studies and requirements.
- EPC shall fulfil all such requirements which may be evaluated as a part of completeness of the technical specification and performance guarantee.

CHAPTER F – DOCUMENTATION

- In this chapter, list of documentation required are indicated for engineering, project management and project execution, Testing and commissioning, operation and maintenance of the project, statutory clearances, approvals etc.
- EPC shall be prepared to provide all such information, drawings and document required to Owner for necessary approval.

CHAPTER G – O&M CONTRACT

- Indicative guidance is given to the owner to detail out the requirements of O&M portion of the contract.
- Owner shall decide the contract period of this project based on the owner expertise and requirement.
- EPC shall be prepared to fulfil the requirements of the owner including manpower.

CHAPTER ANNEXURES

- In this chapter, list is indicated which provides additional details to EPC for designing the filling station, this includes raw water quality parameters, topological and soil investigation details, ICS etc.
- EPC is required to utilise data thus provided by the Owner for fine tuning the design.

CHAPTER ADDITIONAL INFORMATION

- Owner can utilise this information as a part of the contract document in order to ensure the required equipment and system are provided for the continuous, reliable and safe operation of this project.
- This includes list of standards, PG Test procedure, special terms and conditions, training, tentative layout etc.

A. GUIDANCE TO OWNER

1. Deciding factors for Hydrogen Fuelling Station

Before establishing any Green Hydrogen Fuelling Station, the Owner shall evaluate the details pertaining to FCEVs, hydrogen, Costing, Power (source and quantity), Water and Land.

This is to ensure the required inputs are available, cost estimate, manpower availability with the Owner, skill required and importantly the business needs and obligations, environmental requirements etc.,

Owner shall perform the below activities for deciding the input and requirements from this project

1. How many FCEVs need to operate along with range (km/day) of operation for each FCEVs.
2. Collect all the details like hydrogen pressure, storage capacity etc. of FCEVs,
3. Collect the details of the input RE required and its source. Check with the local discom for the voltage level, capacity, open access requirements, tariff and other details.
4. Owner shall decide the operation of hydrogen fuelling station either with only solar power or through RE RTC power.
5. Calculate the sizing of electrolyser, compressor, hydrogen storage, BESS capacity etc., based on the above point no.4.
6. Calculate the total power requirements based on the RE power availability and above sizing details. For example, RE RTC power requirement of 65 kWhr per kg of H₂ dispensing into FCEVs, necessities input power of 1.4 MW with 18000 kWhr/day for producing 250 kg/day of hydrogen.
7. Calculate the water requirements for electrolyser, cooling system, fire water, maintenance activities and others. For every kg of hydrogen requirement, 10 litres of DM Water and 20 litres of raw water need to be considered. If sea water is envisaged, then raw water requirement of 30 litres is to be provisioned.
8. Calculate the land requirement for setting of above equipment and to provide required clearance between the equipment's for the safe and reliable operation, statutory requirements.
 - a. Case-1: Solar Power Usage only
 - i. Less than 100 kg of H₂ with 5 buses – Area required upto 1.2 acres
 - ii. 100 to 300 kg of H₂ with 5 buses – Area required upto 2 acres
 - b. Case-2: RE RTC power is used, the electrolyser capacity will be reduced to half and area required will be reduced by 10%.
9. Owner has to decide the above requirements and calculate the investment cost for establishing the hydrogen mobility project.

For example, Mobility project for 250 kg/day of H₂ generation and required to fuel 05 nos. of FCEVs along with infrastructure is ~₹75 Cr. (excl. OPEX and FCEVs).

2. Layout and Clearance requirements

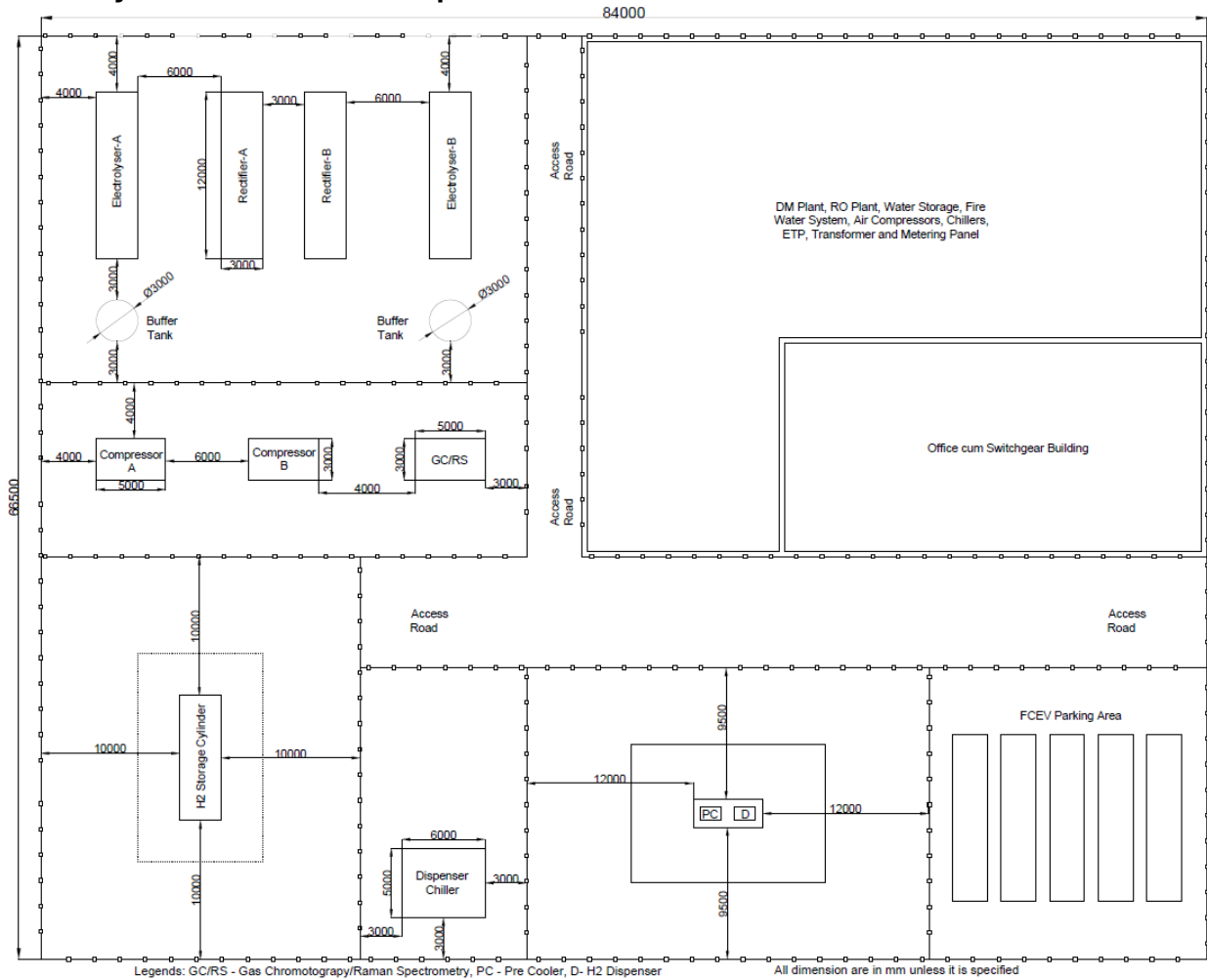

Fig. 1: Tentative Layout¹ with inter distances between the equipment's

Land requirement for the establishment of Hydrogen Mobility Project depends on the following details

1. Storage Capacity of the Hydrogen in kg. – Sizing and quantity of H2 storage cylinders and separation distance around the cylinder cascade.
2. Electrolyser capacity. - Sizing
3. No. of FCEVs. – Sizing of electrolyser, compressor and chiller system
4. Fire protection scheme. – Sizing and separation distance
5. Rate for fuelling of hydrogen into FCEVs. – Chiller sizing

For example, As per PESO requirement, the clear spacing of the storage cylinder is based on storage capacity in water litres (WL). Inter distance from buildings and outer boundaries to gas storage units

Total capacity of gas storage cascade units (WL)	Minimum distance from buildings and boundaries (meters)
Up to 4500	3.0
> 4500 to < 10000	5.0
> 10000 to < 100000	10.0

¹ Detailed layout with inter distance are provided in the additional information Section-V.

3. Project Management and Lead Time

List of 10 equipment having significant procurement times are mentioned below. By implementing structured planning and execution strategies, Owner can focus key activities that significantly impact the project set up time.

A. 10 equipment of filling station having significant procurement time²

Sr. No.	Particulars/Items	Lead time (Month)
A.	FCEV Buses	12
B.	Hydrogen Fuelling Station	
1.	Compressors	8
2.	Storage Tanks with cascade, piping & fittings	6
3.	Electrolyser	6
4.	Gas Chromatograph	6
5.	High Pressure Tubing	5
6.	Rectifier	4
7.	Hydrogen Dispenser	4
8.	BESS	4
9.	PLC System	3
10.	HT and LT Switchgear and Transformers	3

B. 5 civil works with maximum lead time

Sr. No.	Civil Works	Lead time (Month)
1	MCR Building	4
2	Electrolyzer and rectifier foundation	1.5
3	Storage cylinder foundation and firewall	1.5
4	Fire and Raw Water tank foundation	1
5	Compressor foundation	1

² This indicative time required for the design and supply of the equipment's considering that required approval has already obtained from the statutory regulator. If the equipment is of new design and product introduced, the approval time required from statutory regulator can be added.

C. Project Execution Timeline

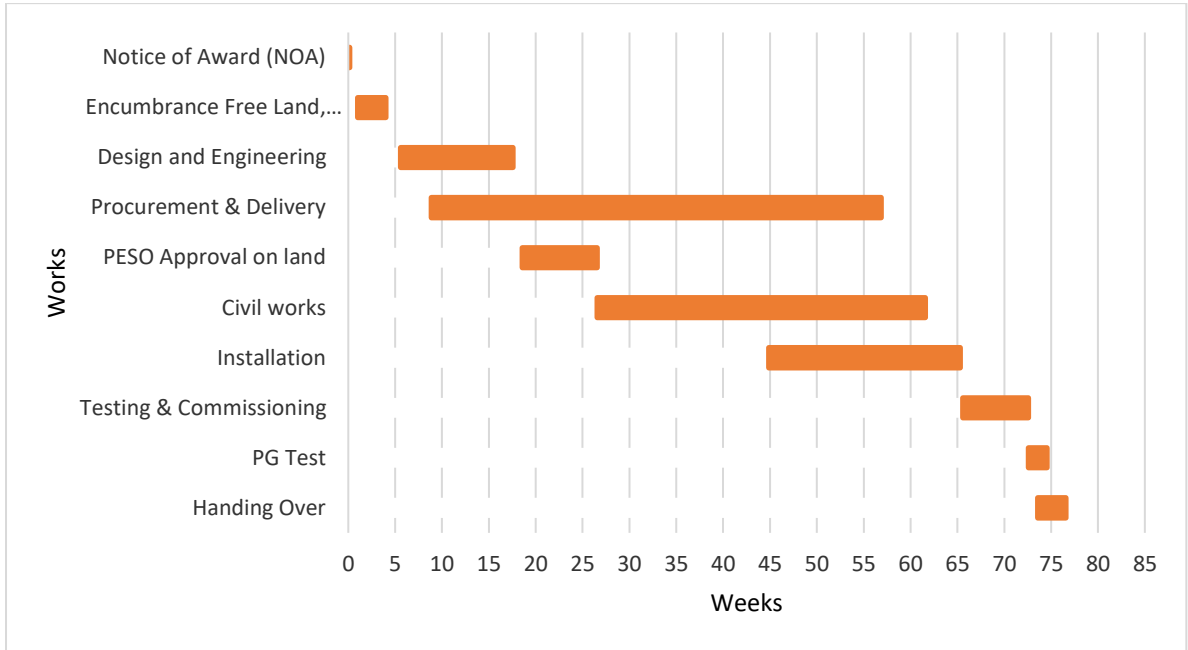

Fig. 2: Bar chart for Project Execution

In view of the time required in above mentioned activities, it is recommended to place order of mentioned equipment's immediately at start of project and run all the civil works simultaneously for better management of time and resources.



4. Cost Estimate³

In implementation of the project, cost estimation and financial analysis acts as one of the deciding factors for the project. Financial viability is a cornerstone of successful project implementation by the organization. Cost estimation and analysis are therefore essential to ensure project success.

Cost contribution of different segments in the hydrogen mobility project:

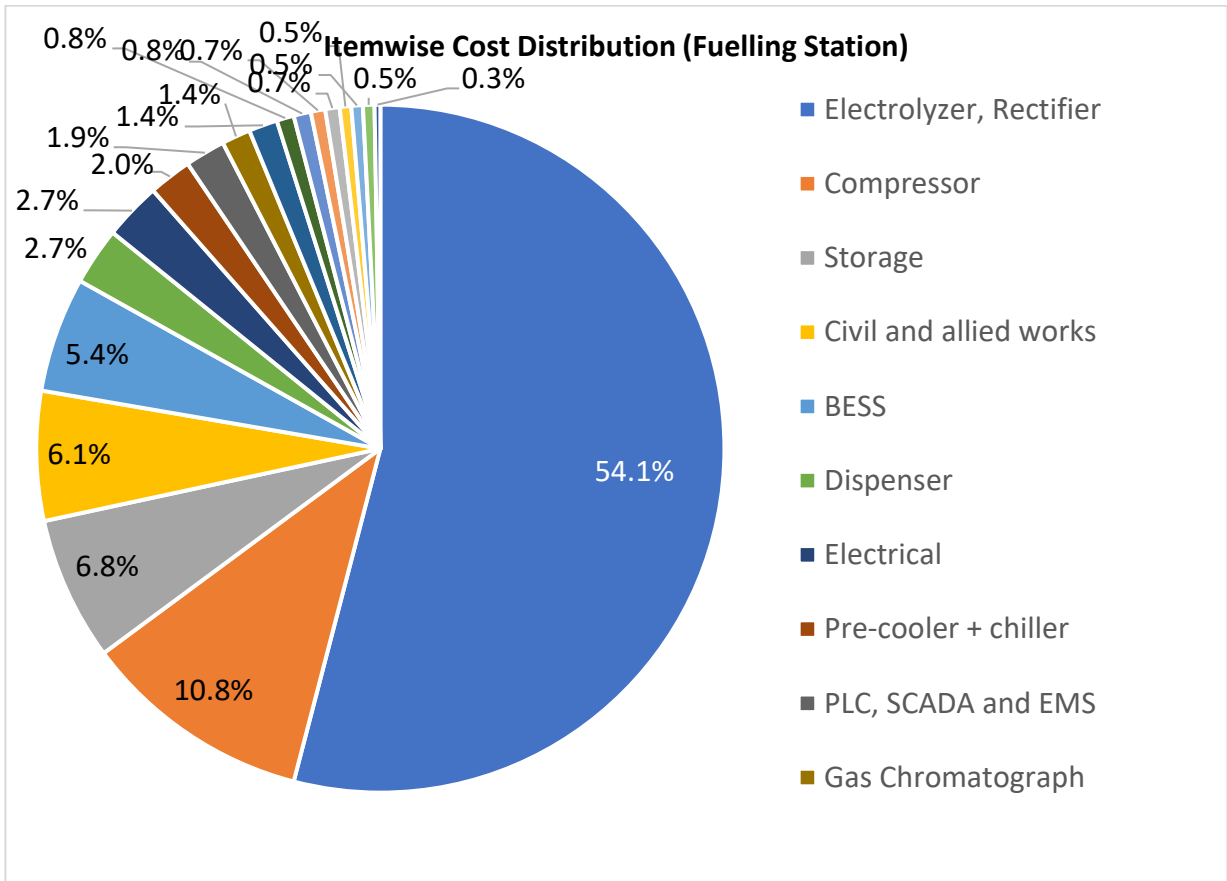

Cost contribution of different segments in the FCEVs:

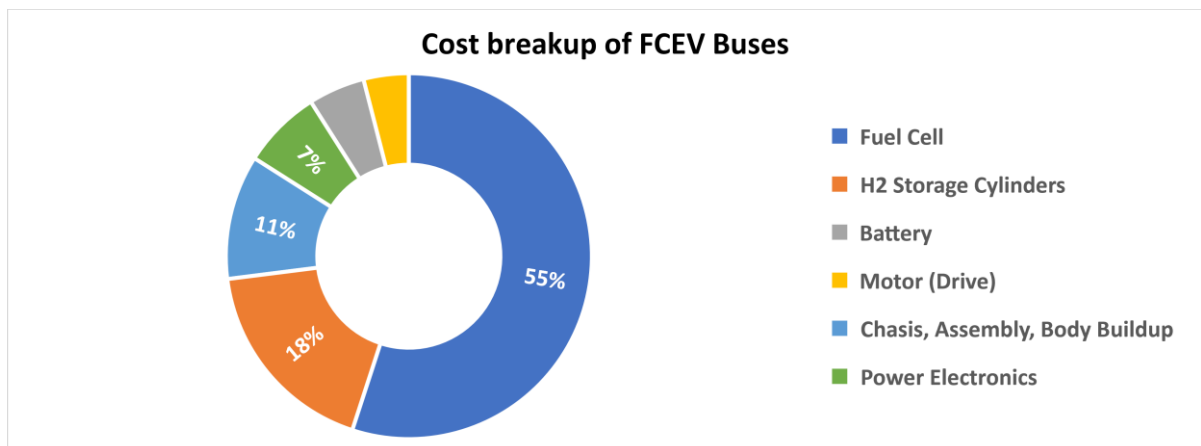

³ This is only indicative cost contribution of green hydrogen mobility with only solar power and hydrogen capacity of 300 kg/day and FCEVs.

B. PROJECT INFORMATION

1. Introduction

COMPANY _____ intends to set up green hydrogen fuelling station at **LOCATION** _____, India. It is intended to generate _____ kg/day of green hydrogen so that _____ nos of FCEVs will have the requisite fuel. It shall have a dedicated facility for Hydrogen Generation, Compression, Storage, Dispensation system and other allied works.

2. Location

The locational details of the proposed project site are as indicated below:

Latitude ⁰'"N
Longitude ⁰'"E
Height above mean sea level m
Seismic Zone
Distance fromtown km
Distance from national highway No. km
Distance from state highway No. km
Distance of nearest airport km
Distance of nearest seaport km
Distance of nearest railway station km

3. Climatological Data

Highest temperature reaches in last decade (°C)
Lowest temperature reaches in last decade (°C)
Relative Humidity: Maximum %
Minimum %
Heaviest rainfall in 24 hours so far cm
Maximum wind speed km/h

Design ambient temperature ⁴ (unless specified otherwise)	___°C to ___°C
Wind Rose diagram of the location shall be provided by owner.	

⁴ Owner can decide the design temperature based on the highest and lowest temperature with safety margin by considering the future requirement.

4. **Near vicinity building and infrastructure**

Owner shall provide the details of important buildings, educational institutions, health care facilities, place of worship etc.,

Nearest Hospital..... km
Nearest School/College km
Nearest Shopping Mall km
Nearest Religious Places..... km



C. SCOPE OF WORK

1. Intent of Specification

- 1.1 This specification is intended to cover the activities and services in respect of the execution of complete Hydrogen Fuelling Station, from electrolyser to dispenser (along with storage) for _____, India. Broad scope of work is specified in subsequent clauses.
- 1.2 It is not the intent to specify completely all aspects of design and construction. Nevertheless, the equipment and civil works must conform to high standards of engineering, design and workmanship and shall be capable of performing continuous operation, in a manner acceptable to the Owner, who will interpret the meaning of the specification, drawings. Also, the Owner shall have a right to reject or accept any work or material which in his assessment is not adequate to meet the requirements of this specification and/or applicable Indian/International standards mentioned elsewhere in the specification.
- 1.3 Bidder is required to carefully examine and understand the specifications and seek clarifications, if required, to ensure that they have understood the specifications. The Bidder's offer should not carry any sections like clarifications, interpretations and/or assumptions. However, if the Bidder feels that, in his opinion, certain features brought out in his offer are superior to what has been specified, the same maybe highlighted separately. The interpretation of Owner in respect of the scope, details and services to be performed by the Bidder shall be binding unless specifically clarified otherwise by the Owner in writing. Therefore, Bidder is advised to seek all such clarifications as required by him, prior to submitting of the techno-commercial bid proposal.
- 1.4 Where-ever the national and international standards are mentioned, the latest standard version with its amendments is applicable.

2. Design Requirements

- a. Facilitate inspection, cleaning and maintenance with the care to safety in operation and personnel protection.
- b. Minimize turnaround times.
- c. Provide safety, reliability and flexibility of service.
- d. Adequate provision for future expansion and modification.
- e. Maximum interchangeability of equipment.
- f. Desired level of operator interface to achieve co-ordinated efficient and failsafe operation, data logging and maintenance of the equipment.
- g. Minimize fire risk.
- h. Automatic protection of all mechanical and electrical equipment's.
- i. Equipment and machinery within the design operating limits.
- j. Adequate provision for future extension and modification.
- k. Suitability for applicable environmental factors.
- l. Equipment with adequate capacity.
- m. Control and indication.
- n. Energy efficient equipment (motors, lighting fixtures).

- o. Aesthetics (as per owner requirement).
- p. Required redundancy (based on specific process / operating needs) shall be built in for the continuity in operation at full capacity is achieved.

3. Brief Scope of Work

- 3.1 The bidder shall be responsible for the design, engineering, supply, construction, erection, testing, commissioning of the hydrogen fuelling station, including civil and architectural works with _____ years⁵ of operation and maintenance (O&M) works of all systems on turnkey basis.
- 3.2 The equipment/system/documentation as below, are in the scope of bidder:
 - a. _____ kW Hydrogen generation system for generating min _____ kg/day hydrogen.
 - b. Hydrogen compression system to compress the hydrogen to a pressure of _____ bar of rated capacity of _____ kg/hr.
 - c. Hydrogen storage facility to store _____ kg at _____ bar in H2 cylinders cascades.
 - d. Hydrogen Dispenser system to fill requisite hydrogen for _____ numbers of FCEVs at _____ bar.
 - e. Battery Energy Storage System (BESS) of _____ kW/ _____ kWhr to support electrolyser coolers, other critical equipment's and control system.
 - f. Complete civil and electrical works with integration of HT System, H2 generation, compression, storage and dispenser system and BESS including office cum switchgear building.
 - g. Unified Integrated Control System (ICS) incl. SCADA and EMS for the control and monitoring of the entire plant.
 - h. Conducting safety studies of Hazard and Operability (HAZOP), Safety Integrity Level (SIL), Hazard Identification and Risk Assessment (HIRA), Quantitative Risk Assessment (QRA), Hazardous area classification (HAC), Escape Muster and Emergency Response Analysis (EMERA), Disaster Management Plan (DMP).

4. Detailed Scope of Work

- 4.1 Compressed hydrogen gas dispensing station shall be designed, constructed, operated and maintained in accordance with NFPA, CGA H-5 and ISO 19880.
- 4.2 The hydrogen fuelling station comprises the following systems:

Sl. No	Description	Quantity
1	Hydrogen generation system (Electrolyzer and its accessories)	1 Lot
2	Hydrogen compression system with all accessories	1 Lot

⁵ Owner has to fill how many years of O&M has to be part of this contract.

3	Hydrogen storage system	1 Lot
4	Hydrogen dispensing system (Selection of storage system through priority panel)	1 Lot
5	Complete Civil and Electrical Works	Lumpsum
6	O&M of complete system (Including operation, preventive and breakdown maintenance along with supply and replacement of spares, consumables, fulfilling statutory requirements etc., housekeeping, security)	___ Years

- 4.3 The completion of all facilities, including commissioning of the hydrogen fuelling station should be completed within _____ months⁶ from the date of placement of award.
- 4.4 Effluent Treatment Plant (ETP) along with neutralizing pit, regular disposal of RO membrane and sludge disposal system shall be in the scope of the bidder.
- 4.5 Zero Liquid Discharge (ZLD) system shall be provided for the complete plant.
- 4.6 Non evaporative type, closed cycle for all the heat exchangers shall be provided.
- 4.7 All licence fees, technology fees, customs clearance (including reconciliation with customs authorities as required), custom duty charges and port clearance, port charges, statutory requirements, and clearance, if any, shall be under scope of bidder.
- 4.8 Obtaining necessary clearance from all the local administration and statutory regulator.
- 4.9 The safety, security and housekeeping of the hydrogen fuelling station will remain with the bidder during the total execution, commissioning, trial run, PG test and O&M period of the contract.
- 4.10 Temporary porta-cabins with basic furniture and washroom facility are required to be setup separately at site for use by owner and bidder shall be provide by bidder till the completion of all facilities in hydrogen fuelling station. Temporary arrangement for works, testing lab, storage shed, accommodation for labour and staff, site office shall be arranged by the bidder.
- 4.11 Arranging construction power and construction water for setting up of the project, besides arranging potable water for labour and other personnel at the worksite/colony.
- 4.12 Office cum switchgear building shall comply with Super ECBC standard. All construction material including cement, wood, reinforcement and structural steel, mud (as per applicability), stone, coarse and fine aggregate and finishing items etc. shall be arranged by the bidder. Pre-Engineered Building (PEB) components can be considered, if required.
- 4.13 Usage of fly ash bricks for all construction activities need to be followed.
- 4.14 Supply⁷ and installation of solar rooftops in the available space of Office cum switchgear building with on-grid and off-grid capability shall be provided.
- 4.15 Providing complete drainage arrangement including any dewatering, site approach and service roads shall be ensured.
- 4.16 Pavement shall be done for the complete facilities.

⁶ Owner can mention the contract period for the complete package completion.

⁷ Owner can define the installation capacity with required performance ratio.

- 4.17 Site grading including slope protection, ground preparation/filling/levelling, compaction of the identified area for the hydrogen station.
- 4.18 Civil/Foundation works for Office cum Switchgear complex, Electrolyser system, Hydrogen Storages, Hydrogen Compression unit, Hydrogen Dispenser, Switchgear, Electrical Panels, SCADA Panels, Batteries, Control room equipment(s), BESS, transformer etc.,
- 4.19 3D model of the Hydrogen Fuelling Station built to scale (for placing inside the model room) shall be provided.
- 4.20 The interiors of the building must be furnished with premium furniture, sanitary and light fittings.
- 4.21 Appropriate number of CCTV cameras (high resolution, manual and digital focus with night colour vision) for at least 15 days storage of data to be provided to cover entire hydrogen fuelling station (area indicated in the site map). The feed from the CCTV camera system shall be made available locally at control room & security room and remotely from any part of the country.
- 4.22 Connecting roads for vehicular movement and enough space for staff and visitor vehicle parking to be provisioned.
- 4.23 Facilities for FCEV maintenance and development of parking area for FCEVs.
- 4.24 Brick or concrete boundary wall (3 meter from FFL) with plastering and concertina wire fence for outer area of hydrogen fuelling station complex and wire mesh boundary wall for internal area of hydrogen fuelling station along with landscaping and façade.
- 4.25 Water supply pipe work for maintenance, horticulture etc.,
- 4.26 Sanitary and plumbing works including connection with existing service networks.
- 4.27 Crash Guards to be suitably installed based on layout of the project.
- 4.28 Display board/Billboard/LED/Neon signages.
- 4.29 Arrangement of drinking water cooler cum heater of 150L and 30L capacity of each 2 nos and establishment of pantry facilities.
- 4.30 All architectural works are required for aesthetic view of station.
- 4.31 Horticulture work based on the inputs by Owner is to be implemented.
- 4.32 Cutting, clearing, transporting and disposal of trees, plants, bushes, other vegetation, roots, stubs etc. as required for the construction of station and regular O&M is under bidder scope
- 4.33 Pavement and gravel base to avoid weed growth is required in area of electrolyser, compressors, storage vessel and transformers etc. Bidder shall ensure no stagnation of water in plant and suitable routing of runoff rainwater.
- 4.34 All works shall be carried out meeting the requirements of this specification. However, for any additional details, then provisions of CPWD specification, National Building Code (NBC) shall be followed.
- 4.35 All incidental items not shown or specified but reasonably implied or necessary for the completion and proper functioning of the hydrogen station, all in accordance with the specifications including revisions and amendments there to as may be required during the execution of work.
- 4.36 All equipment, materials and services whether explicitly stated or otherwise and that are necessary for the satisfactory operation of different systems is in the scope of the bidder.

D. TECHNICAL SPECIFICATIONS

1. Brief Input and Output of the System

Table-1: Inputs and outputs

Sl. No.	Description	Parameters
1	Duration of operation of Electrolyzer	__ hours (__ AM to __ PM) / Continuous Operation
2	Land available	____ acre including parking of FCEVs, Hydrogen fueling station and office cum switchgear building. The owner shall provide the encumbrance free land, with required set back. ⁸ Topological and Soil Investigation details is be provided in Annexure-V.
3	Raw Water	River/Sea/Treated sewage or wastewater for utilities and potable water for office. Water quality details is be provided in Annexure-II. Point of connection is not less than ____ meters
4	Electrical power input	__ kV, 3-Ph, 50Hz, AC power / DC Power Point of connection is not less than ____ meters from the RMU.
5	Discharge/Drain output	Zero Liquid Discharge System

2. Brief requirements of the System

Table.2 Hydrogen generation system

Sl. No.	Parameter	Specification
1	Electrolyser Technology	Any variant of bi-polar type ⁹ complying to ISO 22734:2019 / IS 16509:2020
2	No. of Electrolyser Units	Capacity: 1x100% or 2x50% or 3x35% (independent streams of operation starting from rectifier till compressor)

⁸ Owner can provide the topological and soil investigation report of the existing site location. If not available, it can be included in the bidder scope.

⁹ O₂ concentration should not exceed 0.5% V/V in Hydrogen at Electrolyser outlet till service life of the stack. H₂ concentration in O₂ should not exceed 2.0% V/V at Electrolyser outlet till service life of the stack.

3	Hydrogen generation	Min. _____ kg in max. ____ hours of operation
4	% Purity	≥ 99.97% (ISO 14687: 2019 Grade D)
5	Start-up time (warm)	≤ 15 minutes ¹⁰
6	Storage facility for water (DM and raw water each), with level indicator, level switches and level transmitters	Sufficient to hold one day requirement for hydrogen generation
7	De-Oxo and Dryer unit per electrolyser	De-Oxo (1 x 100%) Dryer (1 Working + 1 Regenerative)

Table.3 Hydrogen compression system¹¹

Sl. No.	Parameter	Specification
1	Compressor Technology	Diaphragm/Ionic/Hydraulic
2	No. of Units ¹²	Capacity: 1x100% or 2x50% or 3x35% (independent streams of operation)
3	Compressor Capacity	Min. _____ kg/hr.
4	Compressor Outlet Pressure	_____ bar
5	Compressor Outlet Temperature ¹³	_____ °C
6	Standards	API 617/API 618

Table.4 Hydrogen storage system¹⁴

Sl. No.	Parameter	Specification
1	Type of H2 Storage Cylinder / tubes ¹⁵	Type 1/2/3/4
2	No. of bank/rack	2 or 3 in cascade format

¹⁰ Bidder to keep provision for heating during shutdown period (non-sunshine hours) so that stipulated start-up time is adhered to.

¹¹ Bidder shall supply the compressor system with the approval from CCoE, PESO

¹² Appropriate standby compressor is of Owners choice.

¹³ It is optional requirement; Owner can specify this parameter for the optimizing the storage capacity.

¹⁴ Diameter of hydrogen storage cylinders used for filling and storage of CHG shall not exceed 80 cm with approval from CCoE, PESO.

¹⁵ Hydrogen storage tubes are preferred for the bulk hydrogen storage more than 200 kg, typically exceeds 5m in length. Type-4 is a must requirement, if the ambient temperature is less than 25°C.

3	Storage Capacity (Usable)	Min. _____ kg
4	Storage Capacity (Total)	_____ kg
5	Storage Pressure ¹⁶	_____ bar
6	Standards	ISO 12245 / ISO 11119 / ISO-10961/ EN 17533 / EN 17339 / BS EN-13769 / BS EN-13807

Table.5 Hydrogen dispensing system¹⁷

Sl. No.	Description	Parameter
1	Type (H35) and Cars (H70)	T40 dispenser
2	Fueling Protocol	Fast filling SAE J2601-05:2024 through MC method
3	Communication protocol	SAE J2799:2019 with IR communication
4	Fueling Method ¹⁸	Double Nozzle (Simultaneous fueling)
5	Operation of dispensing fuel	Through priority panel (Selection of storage system & fueling the FCEV)
6	Parameters display	Pressure, flow rate, temperature of hydrogen fuel dispensing to FCEVs with totalizer.
7	Additional Safety Features	a. Protective jacket over hoses b. Safety controls during fueling process <ul style="list-style-type: none"> • Hose break • High hose pressure or abnormal ramp rates c. Shrouded breakaway connectors (prevent the release of hydrogen)
8	Special Features ¹⁹	a. Display of H2 purity in Dispenser by interfacing with Gas Chromatography / Raman Spectrometry. b. Provision for Automatic Payment System (interfacing digital transaction)

¹⁶ As on Aug 2024, PESO has given the following approvals for the storage cylinder at various pressure levels of different types (Type-1 for 500 bar, Type 3 for 450 bar and Type-4 for 381 bar)

¹⁷ Bidder shall supply the dispenser system with the approval from CCoE, PESO

¹⁸ Owner can decide the fuelling method of dispensing with single nozzle for upto to 5 FCEVs with less than 50 kg.

¹⁹ Owner can decide the feature requirement based on the operational requirements.

Table.6 BESS²⁰

Sl. No.	Parameter	Specifications
1	Rated energy (useful capacity)	_____ kWhr
2	Rated power (Net)	_____ kW at MCC end.
3	Type of battery	Ni-Cd / Ni-MH / Li-ion / Sodium-ion
4	Connectivity	Standalone mode as well as in tandem operation (off-grid and on-grid) Fast Response less than 100ms
5	Round-trip Efficiency	Min. 90%
6	Power Quality	CEA, Grid Code regulations, IEC, IEEE
7	Features (Automatic)	EMS, BMS and TMS



²⁰ BESS of suitable capacity is included to cater the need of critical drives (excl. UPS but incl. compressor, electrolyte coolers, fire water jockey pump etc.,) in-case of RE RTC power. If the Solar power is only sourced, BESS cater the above requirement and non-sunshine hours operation of the station.

3. Detail System Requirements

3.1 Electrical

3.1.1 The bidder shall be responsible for the complete system starting from drawl of AC power from RMU of Discom's to Switchgear MCC including stepdown transformer for hydrogen generation, compression storage, dispensing of hydrogen in FCEVs and other auxiliaries.

3.1.2 Statutory Requirements

The following statutory regulations of relevant clauses shall be followed for design of electrical system.

- a. Indian Electricity Act and Rules.
- b. The Factories Act.
- c. The Gas Cylinder and SMPV Rules.
- d. Other statutory bodies as applicable, e.g. CEA / State Electrical Inspectorate etc.,

3.1.3 Electrical Equipment's

- 3.1.3.1 All electrical equipment's shall be of higher efficiency (IE3 or better).
- 3.1.3.2 Equipment's installed in hazard zone shall be of flameproof and explosive proof. It shall also comply with NFPA, IEC, IS-5571 and IS-15142 etc., Ordinary industrial electrical shall not be used in zone 2 areas.
- 3.1.3.3 Electrical equipment for hazardous area shall be certified by testing authorities like CMRI / CIMFR / CPRI / ERTL or equivalent recognized independent test house such as BASEEFA / LCIE / PTV / UL / FM / ATEX / CENELEC / PTB, UL / FM. All equipment's (indigenous and imported) shall also have valid statutory approval i.e. CCoE, PESO.
- 3.1.3.4 All electrical equipment's shall be provided with suitable canopy for weather protection.
- 3.1.3.5 All panels, distribution boards, junction boxes installed in outdoor environment shall be of IP 67/68 protection. All bus bars shall be weatherproof IP55 with suitable seal and canopy.
- 3.1.3.6 Maximum surface temperature shall not exceed the ignition temperature of the gases as indicated by the T Class (T1- T6) of the apparatus as defined in IEC 60079 / IS 8239. The minimum temperature class to be considered as T3.
- 3.1.3.7 Critical loads e.g. Fire Station supply shall have two supplies from different power sources.
- 3.1.3.8 Design the power system to adapt and maintain the power quality parameters (harmonics and power factor etc.,) as per IEC 519, IEC 61000, IEC 62586, IEEE, CEA, Grid Code regulations.
- 3.1.3.9 Insulation coordination between the electrical equipment and the protective devices shall be done in line with IS 3716.

- 3.1.3.10 Control supply of local panel of critical loads, air compressor shall be provided with UPS.
- 3.1.3.11 Electronic cards of system like UPS, battery charger, VFD, SCADA, Heater, control system shall be ISA-G3 compliant as per Std. S.71.04 with Conformal coating is to be provided.

3.1.4 Switchgear

- 3.1.4.1 All HT and LT breakers shall have numerical relay for the protection, remote operation, and monitoring with LOTO provisions.
- 3.1.4.2 HT breaker shall be provided for the motor rating above 120 kW. Motors rated above 55 kW & upto 120 kW shall be controlled through ACB & motor protection relay and shall be fed from PCC.
- 3.1.4.3 All MCC switchboards shall have two bus sections each with provision for auto and manual changeover scheme through Sync. Check relay. Auto change over scheme shall be provided through logic in Numerical relay of bus coupler.
- 3.1.4.4 Fast bus transfer (FBT) scheme is to be provided in switchboard having high residual voltage during voltage dip.
- 3.1.4.5 HT and LT breakers and LT module shall be of metal clad and draw-out type.
- 3.1.4.6 All HT and LT incomer shall have Tri-Vector Energy Meter and/or net metering with interfacing provision for metering purposes and as per CEA/CERC guidelines.
- 3.1.4.7 In switchgear room floor shall have an electrical insulation coating of ___kV and 415V in accordance with IEC/ISO standards.
- 3.1.4.8 Bus-section feeder/circuit breakers shall have rating whichever is higher of the maximum connected load or bus-bar current rating.
- 3.1.4.9 Incomers of these switchgears shall be designed to cater to the complete load including 20% margin for future load growth.
- 3.1.4.10 Electrical running loads shall be uniformly distributed on each bus, and it shall be ensured that running and standby loads are fed from two different bus sections.
- 3.1.4.11 HV Switchgear shall comply with IEC 62271-200, IEC60470 and equivalent Indian standard.
- 3.1.4.12 Short circuit calculations shall be based on IEC 60909 /IS 13234.
- 3.1.4.13 All PTs shall be provided with additional Open Delta Tertiary winding with damping resistor.
- 3.1.4.14 Earth fault protection shall be provided with CBCT for providing sensitive E/F protection.
- 3.1.4.15 All the bus sections are to be designed for continuous parallel operation
- 3.1.4.16 Each PCC should be fed by two identical incomers and a bus coupler. Only four pole breakers in Incomer and Bus-coupler to be used in PCC.
- 3.1.4.17 Minimum 20% spare feeders or one no. of each rating and type on each side of the bus section whichever is more shall be provided.

- 3.1.4.18 All motors feeders rated above & including 15.0 kW & upto 55 kW shall be controlled through switch fuse unit, contactor, overload relay with CBCT, ELR for earth fault protection & shall be fed from MCC.
- 3.1.4.19 All TPN switch fuse feeders rated 250 A and above shall be provided with ammeter. All emergency / critical drives, irrespective of ratings, shall be provided with ammeter.
- 3.1.4.20 All Bus incomer breakers up to the PCC level shall be provided with the Under Voltage Tripping protection with time graded for various voltage levels.

3.1.5 Bus Duct

- 3.1.5.1 HV bus duct shall be phase segregated type, and MV & LV bus duct shall be non-phase segregated type with support structure would be of galvanized iron.
- 3.1.5.2 Bus bar material shall be electrolytic aluminium / copper with flexible expansion joints.
- 3.1.5.3 Bus insulators shall be non-hygroscopic, non-inflammable and flame retarding type.

3.1.6 Motors

- 3.1.6.1 All motors shall have class F insulation with temperature rise limited to class B.
- 3.1.6.2 Motors fed from variable frequency drive in hazardous area application shall be type tested as unit with the VFD panel. Input power supply for VFDs up to 150 kW shall be 415V AC and 3.3 kV for VFDs above 150 kW.
- 3.1.6.3 Microprocessor based variable speed drive shall be communicable type and shall be able to communicate with PLC / SCADA / DCS.

3.1.7 Transformers

- 3.1.7.1 Transformer rating shall suit 20% spare capacity with 100% standby transformers (for power distribution and lighting).
- 3.1.7.2 Distribution transformer upto 2.0 MVA shall comply to IS 1180 part-1 minimum level 3.
- 3.1.7.3 Less than 1000 kVA: oil- filled hermetically sealed type or dry type (if indoor) and 1000 kVA & above: oil-filled conservator type.
- 3.1.7.4 Synthetic fluid (e.g. silicone or ester or bio) shall be used instead of mineral oil.
- 3.1.7.5 Firewall shall be provided between two transformers.

3.1.8 Cables

- 3.1.8.1 Minimum size of high voltage cables shall also be based on the short circuit with stand capacity for a minimum time of 0.25 Sec with backup protection in line.
- 3.1.8.2 Selection of cables shall comply with IS, NFPA, IEC standards and suitable for hazardous areas. Fire protection for cables shall be provided as per IS12459.
- 3.1.8.3 Only screened type signal cables are to be considered in VFD applications.

- 3.1.8.4 All HV cables shall be with stranded aluminium conductor, dry cured XLPE insulated, insulation screened, PVC inner sheathed, armoured & FRLS PVC outer sheathed.
- 3.1.8.5 All LV power cables shall be with stranded aluminium / copper conductor, XLPE insulated, PVC inner sheathed, armoured & FRLS PVC outer sheathed. Copper conductor shall be used for sizes up to and including 10 sq. mm, and for higher sizes aluminium conductor shall be used.
- 3.1.8.6 All control cables shall be XLPE, armoured type with copper conductors, FRLS PVC outer sheath twisted pair overall shielded type.
- 3.1.8.7 All power and control cables shall be in single continuous lengths without any splices or intermediate joints. In no case the joint shall be located in hazardous area.
- 3.1.8.8 All incoming cables to switchgear/UPS/DC system/DBs and other equipment shall be sized for with additional capacity of 10% and Cable for capacitor banks shall be sized for 135 % of the rated capacitor current.
- 3.1.8.9 Copper cables shall be used in UPS ACDB & ACDB to downstream distribution systems
- 3.1.8.10 Cables installed in aboveground enclosed areas shall be fire retardant and have non-propagating, self-extinguishing characteristics in accordance with IEC 60332 and IS 10810 Part 61-64.
- 3.1.8.11 Separate cables shall be provided for AC and DC signal/control circuits
- 3.1.8.12 All cables shall carry the cable tag numbers for easy identification.
- 3.1.8.13 Signal cables i.e. Instrument, communication, fire alarm, LAN and data highway, etc. cables shall preferably not be laid in the same trench/ tray along with electrical cables. In case these are laid in the same trench/ tray, a clearance of minimum 300 mm from electrical cables shall be provided. GI earth strip of earthing grid shall run along the cable trays.
- 3.1.8.14 GI conduits shall be used between trenches and field equipment like motors, control stations etc.
- 3.1.8.15 Lighting cables shall be run along the structures/cables, buried between cable rack and equipment using conduit.
- 3.1.8.16 All cables i.e. HV and LV in concrete cable trenches shall be laid on cable trays only.
- 3.1.8.17 Fireproof coating shall be applied to the cable passing through electrical storeroom/battery bank room.
- 3.1.8.18 HT cable metallic screen SC rating shall be min 1KA for 2 sec of individual core.

3.1.9 DC System

- 3.1.9.1 Independent DC power supply system shall be provided for the following (unless otherwise specified):
 - a. Electrical Switchgear controls.
 - b. DC critical lighting and DC critical drives.

- 3.1.9.2 Each DC power supply system shall include battery bank, charger-cum rectifier and DC distribution board. System should be provided with a redundant battery charger with paralleling operation scheme and auto changeover.

3.1.10 UPS System

- 3.1.10.1 Uninterrupted power supply system shall be provided for critical loads that cannot withstand a momentary interruption in voltage (e.g. critical instrumentation, control, Human machine interface (HMI) for numerical relays, fire alarm, LAN system etc.)
- 3.1.10.2 UPS shall be of redundant (non-parallel) configuration with 2 x 100% capacity and with dual battery banks. Voltage stabilizer shall be Servo -controlled or static (solid state) type.
- 3.1.10.3 UPS system shall be provided with ACDB with two I/C & one B/C scheme with 100% redundancy of feeders on each section.
- 3.1.10.4 Bypass (SCVS) input supply of both the UPS systems shall be from the common source so that 110VAC output of both UPS systems shall remain synchronized with each other and synchronized (no break) transfer (<4ms) can be achieved at downstream ATS in case of failure running/preferred source of the ATS.
- 3.1.10.5 All the incoming power supply sources to the UPS system (UPS-1 / UPS-2 / Bypass) shall not fall on the same power source.
- 3.1.10.6 UPS system shall be sized to have at least 20% additional capacity with 20% additional feeders.

3.1.11 Emergency Power Supply System

- 3.1.11.1 Emergency power supply system, wherever envisaged, shall feed the following:
- (a) Electrical loads essential for the safe shutdown of the plant.
 - (b) Emergency lighting.
 - (c) Communication system.
 - (d) Fire detection and alarm systems.
 - (e) D.C supply systems.
 - (f) UPS systems.
 - (g) Firefighting equipment excluding main firewater pump.
 - (h) Loads critical for process, plant and personnel safety.
- 3.1.11.2 Emergency power supply could be from a different power source or emergency generator as per project design data sheet. Where emergency generator is envisaged, emergency power supply shall be made available within a time period of 30 second from the instant of failure of normal supply.
- 3.1.11.3 The emergency generator shall, generally, not be required to run continuously in parallel with the normal power supply system. However, short time paralleling facility shall be provided for transferring load to normal power supply or other operational needs as required.

- 3.1.11.4 Battery Energy Storage (BESS) to be provided to cater to the emergency power supply system requirement of hydrogen fuelling station round the clock.
- 3.1.11.5 BESS discharging energy capacity at the end of 10 Years shall be 90% of rated energy capacity with round-trip (AC to AC) efficiency shall be 90% or better. It shall have both on-grid and off-grid capability.

3.1.12 Earthing and Lightning System

- 3.1.12.1 Design shall conform to IS:3043 2018 and lightning protection to IS/IEC: 62305, OISD-0180, National Building Code (NBC) and Code of Practice for Electrical Wiring Installations IS 732:2019 will be followed.
- 3.1.12.2 All electrical equipment operating above 110volts shall have two separate and distinct connections to earth grids. Separate earthing grid shall be provided for instrument, control system and electrical power. Separate earthing shall be provided for transformer neutral.
- 3.1.12.3 UPS, DCS, PLC, and other electronic instruments, including electronic relays, shall be provided with copper plate clean earth and kept galvanically isolated from the system and safety earthing.
- 3.1.12.4 Smart online earthing measurement system.
- 3.1.12.5 Lightning protection shall be designed according to the Lightning Protection Level I (LPL-I), as per the requirements of IS IEC-62305 and OISD-STD-180. All the components shall be tested as per IEC 62561.
- 3.1.12.6 Tanks, piping and process vessels and equipment containing flammable liquids or gas shall be earthed by a connection to the earth network, or by bonding to an earthed metal structure.
- 3.1.12.7 Surge protection shall be designed based on IEC 61643 with type-1 SPD.
- 3.1.12.8 Static Electric Discharge system shall be installed at all hydrogen locations (electrolyser, compressor, dispenser, storage cylinder and control and equipment room). Static Electric Discharge system shall have a dedicated earthing system.

3.1.13 HVAC System

- 3.1.13.1 Adequate HVAC system to be provided for the complete set-up including office, equipment rooms including security and driver room.
- 3.1.13.2 Adequate ventilation shall be provided for Battery and Switchgear room.
- 3.1.13.3 Temperature and relative humidity shall be maintained for the human comfort and electronic cards requirements.

3.1.14 Lighting System

- 3.1.14.1 Lighting levels throughout the plant shall comply with hazardous area working conditions of NFPA and IEC standards. It shall also comply with IS 3646:1992 or latest.
- 3.1.14.2 LED fixtures with anti-glare shall be provided for outdoor and indoor lighting. It shall comply with hazardous area requirements.

- 3.1.14.3 Separate emergency lighting shall be provided for complete hydrogen fuelling station.
- 3.1.14.4 Exit Light fixtures shall be provided in ingress pathways, exit doors of all locations with dedicated power source.
- 3.1.14.5 Adequate number of self-contained portable hand lamps and battery-operated emergency lighting units shall be provided for immediate use for buildings where no DC supply is available
- 3.1.14.6 Lighting system shall consist of lighting transformers, lighting distribution boards (LDBs), lighting and power panels, fixtures, junction boxes etc. Outdoor lighting shall be operated based on synchronous timer / photoelectric cell with manual over-riding.
- 3.1.14.7 Lighting distribution board shall have two incomers and one bus coupler. A minimum of 20% MCB outgoing feeders shall be left as spare in all lighting & power Panels.
- 3.1.14.8 The lighting and power panels shall be provided with MCB and ELCB as incomer and Miniature Circuits Breakers (MCBs) for outgoing feeders control and protection of lighting circuits.
- 3.1.14.9 All DB / JB / Fixtures for emergency lighting & critical lighting to be colour coded for distinct identification.

3.2 Mechanical

3.2.1 Mechanical Equipment

- 3.2.1.1 All Piping along with Structure and Equipment's shall be designed as per the Dynamic/Wind/Seismic analysis.
- 3.2.1.2 Welding and Brazing Qualification shall be as per ASME BPV Sec. IX.
- 3.2.1.3 All couplings, gears, and exposed rotating parts shall be provided with adequate protection guards.
- 3.2.1.4 Noise level of the running equipment shall not exceed 85 dBA at 1m distance from source, unless otherwise specified.
- 3.2.1.5 Corrosion allowance for carbon steel vessels shall be minimum 3mm, unless otherwise specified.
- 3.2.1.6 All components/equipment shall meet the requirements of respective hazardous area classification.
- 3.2.1.7 Hydrogen generation can be either containerized standalone outdoor system or installed in the closed civil infrastructure. Clear separation distance between the equipment and outer wall shall be provided with minimum 600 mm in all sides.
- 3.2.1.8 Compression system shall be mounted on the foundation in a closed enclosure with proper noise insulation and well ventilated.
- 3.2.1.9 Hydrogen storage system be provided with well-ventilated shed having a light roof with louvers with at least two sides open. Safe weather protection over gaseous hydrogen storage system shall conform to the provisions of CGA PS-46.
- 3.2.1.10 Container or closed civil infrastructure shall have both active and passive ventilation system to avoid accumulation of hydrogen.
- 3.2.1.11 Hydrogen dispensing system shall provide with separate roof covering dispenser and FCEV buses at both sides.
- 3.2.1.12 All underground vessels shall, tanks, piping shall be provided with galvanic/cathodic protection.
- 3.2.1.13 Non-Destructive Examination shall be performed as per ASME BPV Sec. V
- 3.2.1.14 Layouts for Oil and Gas Installations, safety requirements shall be as per OISD-118.
- 3.2.1.15 All flange joints on piping system including flanges on the equipment, manholes, etc shall be tightened using Hydraulic bolt tensioner and fasteners bolting nuts shall be marked for its tightness confirmation.
- 3.2.1.16 Hot Insulation materials, application etc. shall be based on recommendations of Standard specification for Hot insulation of vessels, piping and equipment of OEM. When operating temperature is below 200 oC, pipe shall be wrapped with Aluminium foil / SS foil (in case of SS lines) prior to insulating the line. All pipes shall be coated with zinc silicate coatings below 120 oC and silicon Aluminium above 120oC. No painting shall be done on SS lines. only Aluminium cladding sheets shall be used.

- 3.2.1.17 All items shall be marked (stamped/etched) in accordance with the applicable code/standard/specification along with the item code/tag no.
- 3.2.1.18 Compressed hydrogen storage cascade shall be designed such that, cylinders are easily removed from the cascade for the periodic testing process.

3.2.2 Piping/Tubing

- 3.2.2.1 Piping/tubing in gaseous and liquid hydrogen service and to pipelines in gaseous hydrogen service as per ASME B31.12:2019 standard with min. stainless steel material. It shall also conform to ISO 15649.
- 3.2.2.2 All piping/tubing must be labelled as per ANSI/ASME A13.1 standard. Associated items such as valves/check valves/filters must be tagged legibly for quick identification.
- 3.2.2.3 Piping/Tubing should be cleaned as per ASTM G93/G93M-19 standard on Oxygen side before putting into commissioning/service.
- 3.2.2.4 Flexible hoses used for hydrogen delivery shall conform to the provisions of ISO 21012.
- 3.2.2.5 All piping systems shall be hydro tested at 1.5 times the design pressure subject to Indian Boiler Regulation-1950, Regulation 374 or ASME B31.12:2019. However, for such systems where it is practically not possible to do hydro tests, the tests as called for in ASME B31.1:2022 in lieu of hydro test shall also be acceptable.
- 3.2.2.6 All fitting shall comply with EC-79 or better standards.
- 3.2.2.7 Piping used for DM Plant and DM water shall be stainless steel with min grade of 304.
- 3.2.2.8 All vents shall be routed to a safe area and in a manner that gas vented out is blown away from the nearest building. Height of vent shall be minimum five (5) meters above ground level. Distance between vent and fence shall be minimum five (5) meters from at least 3 sides. It shall also conform to the specification CGA G 5.5.
- 3.2.2.9 It shall have a separate venting system for electrolyser, compressor, storage, and dispenser. Flame arrestor with temperature transmitter to be installed in all venting points. NFPA-2 Hydrogen technologies compliance shall be followed.
- 3.2.2.10 Piping shall be suitably supported to avoid vibrations and shall be designed so that forces and moments imposed on the compressor do not exceed the OEM's recommendation.
- 3.2.2.11 All carbon steel pipes and fittings having wall thickness 19 mm and above shall be post weld heat treated. All alloy steel (Cr-Mo) pipes and fittings shall be post weld heat treated irrespective of type or thickness of weld. All austenitic stainless-steel grades shall be solution annealed after welding. 100% radiography of welded joints shall be done both before and after PWHT.
- 3.2.2.12 All hoses shall be clearly marked with service and working pressure at both ends. Hoses shall be resistant to ageing, abrasion and suitable for outdoor installations. Complete Hose assembly shall be tested at two times the design pressure.

3.2.3 Valves and Tanks

- 3.2.3.1 All valve castings shall be of radiographic quality. Valves shall comply with ASME SEC-VIII, DIV.1, ASME SEC-V, ASTM stds.
- 3.2.3.2 All solenoid valves, control valves, critical manual valves shall be feedback mechanism about its status.
- 3.2.3.3 The system shall be provided with necessary connection with proper isolation devices, valves, regulators, manifold piping, cylinders, trollies, canopies to enable purging/flushing of the system with nitrogen for commissioning and at each maintenance work.
- 3.2.3.4 Supply and maintaining adequate quantity of nitrogen gas for emergency and O&M activities is in the scope of bidder.
- 3.2.3.5 All storage tanks shall be designed based on API 620 and API 650. DM Water Tank shall be provided with Stainless Steel Material.
- 3.2.3.6 Nozzle flanges up to 600 NB shall be as per ASME B16.5 and above 600 NB shall be as per ASME B 16.47 (SERIES 'B').
- 3.2.3.7 Filter housing design shall be as per ASME Section VIII, Div.1.

3.2.4 Platforms, Pipe Rack

- 3.2.4.1 Proper canopies, ramp protection to be provided at appropriate locations.
- 3.2.4.2 Platforms, ladders & stairways shall be consistent with access & safety requirements.
- 3.2.4.3 Platforms shall be provided with stair access in the case of platforms provided for normal monitoring.

3.2.5 Rotating Equipment's

- 3.2.5.1 Hydrogen compressors are to be located under shed and provision for top venting from compressor sheds shall be provided.
- 3.2.5.2 Compressors shall be located to keep suction lines as short as possible.
- 3.2.5.3 Compressors shall comply with API 617 / 61/ 619. Mechanical Run Test shall be carried out at OEM works.
- 3.2.5.4 Hydrogen compressor health monitoring system (vibration, temperature etc.,) shall be provided through PLC system.
- 3.2.5.5 Belts used for equipment located in hazardous area shall be static non-conducting type and shall be certified suitable for the area classification.
- 3.2.5.6 Separate air compression facility for instrument air as per their system requirements and service air for the maintenance and FCEV requirements.
- 3.2.5.7 Air compression facility shall be provided with auto and manual drain system.
- 3.2.5.8 Pumps for Fire Water Application shall be direct coupled.
- 3.2.5.9 All reciprocating pumps shall comply with API 674/675. Pulsation suppression and dampener shall be provided.



3.2.5.10 Positive Displacement Pump (Rotary) shall comply with API-676 and suitable to run simultaneously at the pressure-limiting accumulation pressure and at trip speed without suffering damage.

3.2.5.11 Pump and compressor drives shall have clear access.

3.2.6 Heat Exchangers

3.2.6.1 Thermal design should be performed using the latest HTRI or HTFS methods and software and shall comply with API 661.

3.2.6.2 All heat exchangers shall be hydrostatically tested and certified in the OEM works in comply with the provisions of the ASME Boiler and Pressure Vessel Code Section VIII and TEMA.

3.2.6.3 Shell & tube heat exchangers, minimum thickness shall be as per TEMA.

3.2.6.4 Air Cooled heat exchangers, minimum thickness shall be as per API 661.

3.2.6.5 Instrument air dryer used shall be any one of the following types: - Heatless purge type (PSA type) / Split flow no purge loss type / Heat of compression type.

3.2.7 Safety Valves

3.2.7.1 CHG cylinder fitted with safety relief devices or pressure relief devices in their bodies or valves, shall have such safety devices manufactured and maintained in accordance with IS: 5903, CGA S-1.1, CGA S- 1.2, CGA S-1.3, UN R-134 code

3.2.7.2 All the Safety Valves shall be **ASME UV code stamped**.

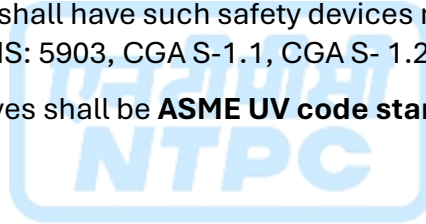

3.3 Instrumentation

3.3.1 Instrumentation System

- 3.3.1.1 Instrumentation System shall be designed based on Safety Instrumented System (SIS) requirement.
- 3.3.1.2 All instrumentation in safety/interlock loop shall comply with IEC 61508 & 61511 and subject to SIL Assessment and its requirements.
- 3.3.1.3 Instrumentation and control system shall in general meet the requirement of API-RP-551, 552, 554, 555 or EN 334, EN 14382 to the extent applicable.
- 3.3.1.4 All transmitters/instruments shall be intrinsically safe, and shall be certified for use in the
- 3.3.1.5 specified hazardous area classification by any recognized authority like CMRS, FM, CENELEC, PTB, BASSEFA etc.
- 3.3.1.6 All solenoid valves shall be IS type with operating Voltage 24V DC (IS) and certified for use in specified hazardous area and shall be SIL-3 certified as minimum.
- 3.3.1.7 Mandatory Requirement: All intrinsically safe and explosion proof instruments, analyser and accessories shall be approved by CCoE, PESO.
- 3.3.1.8 Instrumentation shall be electronic type. Only final control elements shall be pneumatic.
- 3.3.1.9 Performance Track Record (PTR) for all field instruments and for system/subsystem (incl. PLC/SCADA) shall be minimum of 4000 hours.
- 3.3.1.10 All equipment shall meet the ECR/EMC technical requirements of IEC 61000, IEC 61326 and IEEE C37.90.
- 3.3.1.11 Instrumentation system shall be provided with two independent source and Instrument cubicles shall be dual fed and utilise redundant PSU's wired in hot standby mode.
- 3.3.1.12 2-O-O-3 voting configuration shall be used for all input signals to ESD/ SIS.

3.3.2 Environmental protection

- 3.3.2.1 All instruments and equipment shall be suitable for the climatic data of the project.
- 3.3.2.2 All instruments, junction boxes, push button station, control cabinet, panels and enclosures in field shall be IS, dust proof, weatherproof to IP65 or NEMA 4X and secure against the ingress of fumes, dampness, insects and vermin.
- 3.3.2.3 All panels, distribution boards, junction boxes, pushbutton stations, control cabinet, instruments installed in hazards zone shall be of flameproof and explosive proof. It shall comply with ATEX and IECEx directives.
- 3.3.2.4 All the field instruments, analysers and equipment's other than used for H2 service shall be suitable for Zone-I Gr. IIA & IIB, T3.
- 3.3.2.5 Field instruments for H2 service shall be suitable for Zone-1 Gr. IIC, T3. as minimum.

- 3.3.2.6 Enclosures for Analyser's shall be suitable for Zone-1, Gr. IIC, T3 (as per individual hazardous area classification if is not available).
- 3.3.2.7 Instrument enclosure shall be designed with a dual compartment housing that provides metallic isolation between the electronics and the terminal compartments.
- 3.3.2.8 All instruments wetted parts shall be SS316 as minimum and electronic housing material shall be of Epoxy coated die cast Aluminium. For Gas Detector and instruments installed in toxic/corrosive environment SS housing shall be used.

3.3.3 Instruments

- 3.3.3.1 Dedicated online mass flow meter (Coriolis type) and gas analyser shall be provided in each stream of hydrogen generation system and online mass flow meter (Coriolis type) shall be provided in each stream of Compressor and dispenser.
- 3.3.3.2 For all hydrogen application, Transmitter diaphragm shall be gold plated on SS316L & gold plating thickness shall be as per ASTM or process condition, whichever is higher.
- 3.3.3.3 Pressure transmitter(s) should constantly monitor the system pressure. If the system pressure increases out of range, the hydrogen production should be stopped and put in standby. A temperature transmitter should constantly monitor and control the electrolyte temperature (in-case of alkaline electrolyser). The electrolyte levels should be measured by a level transmitter and controlled by a level controller.
- 3.3.3.4 All Transmitters shall be intrinsically safe & SMART type with HART protocol with integral LCD indicator, test terminals and bypass diode.
- 3.3.3.5 Field Transmitters shall be used in place of switches; all inputs to PLC/SCADA shall be through field transmitter
- 3.3.3.6 Proper approach or platforms shall be provided for all locally mounted gauges Field mounted Instruments, where feasible shall be close coupled (post mounted, if it's not feasible).
- 3.3.3.7 Thermowells and orifice plates shall be min. 316 stainless steel. Standard type orifice plates shall be designed as per ISO 5167.
- 3.3.3.8 All remote mounted instruments, including instruments connected to lines or vessels by means of flush or remote mounted diaphragm seals, e.g. transmitters, switches etc., shall be 316 stainless steel minimum unless process conditions require a more suitable material.
- 3.3.3.9 For dispenser, instruments shall have a feature for switching-off of Pressure and Temperature compensation.
- 3.3.3.10 Liquid level applications, remote Diaphragm seal type Smart level instruments shall be used with local indicators.
- 3.3.3.11 Double isolation type root valve shall be provided for the hydrogen application >40 bar and others application >60 bar.

- 3.3.3.12 Temperature transmitters shall be Remote mounted type, dual channel, dual sensor dual compartment, smart transmitter with HART bus protocol, integral output meter, burnout protection and auto change over. It shall be used for all temperature measurements (other type shall be considered, if it is not feasible).
- 3.3.3.13 DM plant and all corrosive service shall have non-contact type level instrument.
- 3.3.3.14 All critical parameters like pressure, temperature, flow, levels shall have both local and remote indications. All critical parameter for operation and emergency shutdown of the station and/or individual equipment shall have 100% redundancy on instruments.

3.3.4 Control Valves

- 3.3.4.1 Control valves size shall be as per IEC/ ISA 75.01 and each valve trim shall be constructed from 316 SS, unless stated otherwise.
- 3.3.4.2 All control valves shall have their predicted aerodynamic / hydrodynamic noise level and comply with IEC 534-8-3 and IEC 534-8-4.
- 3.3.4.3 All control valve actuators shall be provided with SMART positioners, complete with air sets having 5-micron filters and capable intelligent design of transmitting full diagnostic and predictive maintenance data to the PLC/SCADA.
- 3.3.4.4 All ESD and Depressurising valves shall be pneumatically operated and compatible to process material, temperature, and pressure. SIL 1/2 rating valves shall be provided.
- 3.3.4.5 All valves shall be subject to NDE/NDT in accordance with ASME B16.34.

3.3.5 Analyser and Gas Chromatograph (GC) / Raman Spectrometry (RS)

- 3.3.5.1 Analyzer Systems shall comply with IEC 61000-4. Certification from statutory authority like BASEFFA, FM, PTB, CENELEC etc. for items of imported item and from CMRI, ERTL etc. for domestic items.
- 3.3.5.2 Analyzer shelter and analyser location shall be designed to minimize sampling time and easy maintenance. Complete assembly shall be mounted on a free-standing easel type frame, complete with overhead rain / sun protection canopy and clearance.
- 3.3.5.3 Minimum Sampling points at the outlet of electrolyser (H₂ and O₂), compressor and inlet to dispenser.
- 3.3.5.4 GC/RS based analyser system is required for continuous display/record of hydrogen purity, oxygen content (ppm), moisture content (ppm), nitrogen (ppm), argon (ppm) and other components as per SAE J2619 / ISO14687.
- 3.3.5.5 GC/RS system shall consist of complete set of analysers, sampling system, sample-conditioning system, internal power supplies, cabling, inter piping.
- 3.3.5.6 GC/RS shall be provided with redundant power supply and communication to PLC/SCADA.

3.3.6 Tubing and Fittings

- 3.3.6.1 All fitting shall comply with EC-79 or better standards.
- 3.3.6.2 Tubing: SS material, seamless having minimum 2.5% of molybdenum content and carbon content shall be less than 0.03%. Tolerance on wall thickness should be $\pm 10\%$. Testing of the tubing should be in accordance with the DIN/NFA/ASTM/EN standards.
- 3.3.6.3 Fitting: SS material having minimum 17% of chromium, minimum 12% Ni content and carbon content shall be less than 0.05%. All component of the material shall be of same materials and etched. Fitting shall have two ferrule design with grip type. Testing of the fittings should be in accordance with the DIN/NFA/ASTM/EN standards.
- 3.3.6.4 Air distribution main header and all instrument air, N2 piping line shall be of minimum SS304 and tapping as per API standard.

3.3.7 Instrumentation Cable

- 3.3.7.1 All instrumentation cable shall be individual shielded, FRLSH and armoured.
- 3.3.7.2 All cables glands shall be of type 304 SS: double compression type, flame proof with Ex(d) certificate suitable for armoured cables with PVC shrouds.



3.4 Integrated Control System (ICS)

3.4.1 ICS shall comprise of following components as a minimum, but not limited to;

- 3.4.1.1 Controllers capable of performing algorithms and logics relating to analogue control, sequence and interlocks required during start up, shutdown and normal continuous operations.
- 3.4.1.2 HMI required for the operators to monitor and perform control actions as required.
- 3.4.1.3 Servers facilitating access to real time live data and processed/stored data for operations, maintenance and corporate needs.
- 3.4.1.4 Network Printers (Multi-Function, compatible to A3 and A4 paper size).
- 3.4.1.5 Input/Output cards with racks, communication processors and power supplies that can interface to field connect input/output devices.
- 3.4.1.6 Cabinets to house various electronic components with required accessories for power/signal conditioning such as MCB/MCCB, distribution, convertors, barriers and surge protection, and for cable termination and dressing. Cabinets to house the ICS related components shall be designed to ex-proof/flame-proof requirements.
- 3.4.1.7 Communication interfaces for connected package systems on the field-layer and data exchange to the data-layer.
- 3.4.1.8 Network infrastructure with firewall and cyber security and components shall be designed as per IEC 62443.
- 3.4.1.9 Software required for performing various control/monitoring and configuration/maintenance functions.
- 3.4.1.10 Shutdown related inputs shall be hardwired from the local emergency pushbuttons.

3.4.2 PLC and SCADA

- 3.4.2.1 All plant and equipment interlocks shall be executed through PLCs which shall communicate to SCADA/DCS through redundant Direct bus connectivity (preferred) or Modbus protocol.
- 3.4.2.2 QMR/TMR SIL3 PLCs system and architecture shall be used for electrolyser, rectifier, compressor, dispenser, safety system for executing trips/ interlocks.
- 3.4.2.3 DMR PLCs can be used for DM plant, chiller, cooling tower, utilities etc.,
- 3.4.2.4 Maximum Loading of Processor shall not exceed 50% Including all type of installed spare.
- 3.4.2.5 System Electronic cards/hardware for all third-party system, main system and packages like PLC/DCS/SCADA shall be compliant for corrosive environment severity class G3 as per ISA-S 71.04 or equivalent.
- 3.4.2.6 PLC based SCADA for the overall control of the hydrogen fuelling station to be provided. SCADA shall be able to acquire real time data of identified equipment. The SCADA should have historian and should be capable of storing at least one year data.

- 3.4.2.7 PLC and SCADA shall be integrated with Energy Management System (EMS). EMS is to take care of real time monitoring, operation, control, reliable and efficient performance of the hydrogen fuelling station.
- 3.4.2.8 EMS with PLC/SCADA shall have the following facilities for scheduling the electrolyser and compression system operation:
- 3.4.2.9 To start and stop on auto mode based on the Scheduled Generation/Time of the Day (ToD) or both.
- 3.4.2.10 To ramp up / ramp down the loading based on Scheduled Generation of RE power/based on the actual RE generation.
- 3.4.2.11 The required algorithm for the above provisions shall be finalized during engineering stage.
- 3.4.2.12 Selected data shall be provided any of the central offices located anywhere in India through secured web-based client or by any other means. It shall be accessed with proper authentication.
- 3.4.2.13 PLC/ SCADA system shall have provision for interfacing with Owner Server (Data acquisition system). Provision for OPC (optical portable communication) protocol and facility is required for any third-party interface and provide the functionality for remote operation of hydrogen fuelling system.
- 3.4.2.14 SCADA shall have facility to provide real time reporting of alarms and statistical data through SMS and e-mails. Dedicated Internet connectivity shall be provided for the control system.
- 3.4.2.15 Separate Wi-Fi and LAN connectivity shall be provided for the office cum switchgear building.
- 3.4.2.16 SCADA shall have to Interface Zone-1, in-case of the equipment placed outside the hazardous zone / Zone-0 is required in-case the equipment is placed along the hydrogen source.

3.4.3 Control System

- 3.4.3.1 The control room to have all facilities to monitor and control the entire hydrogen fuelling station without requirement of manual intervention and should have PAM (Personnel Area Monitor). PAM system should measure O₂ gas and H₂ gas continuously at site with required alarm annunciation for low (19.5%) and enriched (23.5%) O₂ atmosphere.
- 3.4.3.2 All PLC/CPU shall have 100% redundancy along with power source. The complete process, together with all relevant parameters, should be constantly monitored and controlled by microprocessor(s) with Hot-standby CPU modules for bump less changeover.
- 3.4.3.3 Dedicated UPS system (2 x 100%) shall be provided for PLC and SCADA system.
- 3.4.3.4 Power System and Control System equipment's shall be designed and tested for its cyber security and the guidelines issued by Ministry of Power against Circular no. No.25-l I/6/2018-PG dated 02.07.2020 and Circular No. 12/34/2020-T&R dated 08.06.2021.

- 3.4.3.5 Control System shall be configured for remote monitoring and shall have all infrastructure, internet facilities, web interface portal with GUI and secured access.
- 3.4.3.6 Bidder shall provide one no of industrial grade laptop of min. 15-inch display with all the software's of PLC/SCADA, relays, antivirus, firewall with latest patches.
- 3.4.3.7 In case of malfunction of the microprocessor(s) or in an emergency, the unit should shut down immediately. Safety devices to protect microprocessor(s) against power line disturbance should be provided. The system should be capable of taking electrical surges and wide voltage.
- 3.4.3.8 Minimum requirements of Integrated Control System (ICS) are enclosed in Annexure-VI.



3.5 Safety Systems and Studies

- 3.5.1.1 Adequate safety systems are to be installed for proper monitoring and ensuring healthiness of every equipment and personnel safety on a continuous basis. The certification of all equipment to be done on a regular basis, maintaining the OEM guidelines as well as Indian and International standards. The last date of certification/calibration should be mentioned on the equipment.
- 3.5.1.2 Emergency Push Buttons at different locations (HOS Room, Control Room, Switchgear MCC, Electrolyser, Compressor, Dispenser, Security, Transformer) for emergency isolation and shutdown of the system.
- 3.5.1.3 Temperature and humidity sensors along with air quality sensor like CO₂ loggers shall be installed inside the rooms of office cum switchgear building.
- 3.5.1.4 The Hydrogen station shall be equipped with all required protections to safely shutdown/trip the station locally as well as remotely at certain distance (Area Isolation System-AIS) from the station in any case of emergencies with respect to operation of Hydrogen fuelling station and safety of equipment and persons. The AIS must be hardwired type to isolate the entire H₂ related system.
- 3.5.1.5 Minimum three no's of 80-inch LED screen shall be provided in the Office cum switchgear building (a. HoS (Head of the Station) room b. Conference Room c. Control Room) for display of various real-time parameters.
- 3.5.1.6 Appropriate Safety devices (with 100% redundancy for critical signals) are to be provided for the entire system for safe release of hydrogen, pressure build up etc.
- 3.5.1.7 Hydrogen leak detection 0–100% of LEL, flame detectors, smoke detectors, heat sensors and interlock system (Alarm at 20% of LEL and Shutdown or isolation of equipment/devices at 40% of LEL) shall be provided with 100% redundancy to ensure safety with suitable alarms in the surroundings and system trip interlocks of complete hydrogen fuelling station.
- 3.5.1.8 Bidder shall take necessary regulatory approvals from Petroleum and Explosives Safety Organization (PESO) for the equipment's, components, storage and for the layout of the hydrogen refuelling station complex.
- 3.5.1.9 Hydrogen cylinder shall comply with Gas Cylinder Rules, 2016 and its amendments. Regulations under AIS 157:2020 may be referred and all clearances and approvals to be done for the installed and operational hydrogen system with approval from PESO or authorized test agency as directed by PESO. All product related compliances and approvals are to be provided by the bidder within the project timelines and all site approvals would be in bidder scope.
- 3.5.1.10 Following safety studies shall be carried out by the bidder and any other studies as mandated by statutory guidelines/requirements.
- 3.5.1.11 Hazard and Operability study (HAZOP) of the whole system (Electrolysers, compressor, storage tubes, dispenser etc.) before starting of installation activity.
- 3.5.1.12 Fire and Gas mapping study shall be conducted for Gas, flame and smoke detection devices as per ISA standard.
- 3.5.1.13 Safety Integrity Level (SIL) assessment shall be performed on the complete instrumentation and control system of the project.

- 3.5.1.14 Quantitative Risk Assessment (QRA), Hazardous area classification (HAC) and Escape Muster and Emergency Response Analysis (EMERA) studies (Emergency response plan as per ISO 14001) for the complete system shall be carried out by the agency.
- 3.5.1.15 Hazard Identification Risk Assessment (HIRA) also to be conducted and report to be submitted before completion of Trial operation.
- 3.5.1.16 Disaster Management Plan (DMP) for the complete station shall be carried out (preferably).
- 3.5.1.17 Proper operation of hydrogen gas leak detection system (with 100% redundancy) should be tested before starting trial operation by applying sample gas.
- 3.5.1.18 Gas leakage determination and ventilation are based on IEC/EN 60079 standards. Response time of sensor shall be as minimum as possible.
- 3.5.1.19 Point detection devices and flame detection for the confined space and covering all areas of operation (Electrolyser, Compressor, Storage, Dispenser, GC/RS etc.,)
- 3.5.1.20 Ultrasonic leak detection devices for open space (Electrolyser, Compressor, Storage, Dispenser, GC/RS etc.,)
- 3.5.1.21 Flame detection devices at all locations (Electrolyser, Compressor, Storage, Dispenser, GC/RS etc.,).
- 3.5.1.22 Bidder shall provide the portable ultrasonic type of hydrogen leak detectors with multiple camera, LCD for image display and hazardous area complaint.
- 3.5.1.23 Bidder has the responsibility to get the hydrogen fuelling station including office cum switchgear building layout approved from PESO and any changes being done by bidder must be approved by Owner before putting up for approval by PESO.
- 3.5.1.24 All high-pressure joints shall be of welded constructions and radiographed. All piping/tubing must have integrity of continuity to avoid static energy generation. Accordingly, all piping/tubing must have grounding/bonding provisions.
- 3.5.1.25 All major isolation and critical valves should have/must be installed for easy/proper LOTO (Lock-out/Tag-out) provisions.
- 3.5.1.26 The complete system should have adequate safety provisions required for handling of hydrogen. The system should be designed for safe operation with all the required control instruments, interlocks, alarms, etc. for full safety and emergency provisions for start-up/shutdown and normal operation. If any additional interlock for safe start-up/operation/shutdown of station is identified during design review meeting, FAT/SAT and the same shall be incorporated.
- 3.5.1.27 All necessary instrumentation, isolation valves and safety equipment like safety valves etc to be provided for the safe operation of the pressure vessel.
- 3.5.1.28 Dedicated fire suppression safety device (water sprinklers, water hydrant, CO2 flooding system) shall be provided in electrolyser, compressor, storage, dispenser and other H2 service system. Inert gas system shall be provided in control room and control equipment room. It shall be provided with automatic and manual operation.



- 3.5.1.29 Portable fire extinguishers of DCP, CO2 Cylinders and others shall be installed at different location of Hydrogen fuelling station complex as per PESO, IS and NFPA guidelines.
- 3.5.1.30 The bidder must have necessary first-aid facilities for all his employees, representatives and workmen working at the Site during the project execution and ___ Years of O&M phase.
- 3.5.1.31 Bidder shall display of safety sign boards, evacuation routes, warnings, layouts, MSDS do's & don'ts at locations of the station.



3.6 Civil and Architectural Works

3.6.1 Design and Layout Consideration

- 3.6.1.1 Depending upon the topology the climate zone of the project shall be followed.
- 3.6.1.2 Topographical survey and soil/geotechnical investigation results of the project location is enclosed in Annexure-V.
- 3.6.1.3 While preparing the detailed layout, planning station facilities, the Bidder shall ensure the following aspects:
- 3.6.1.4 All statutory requirements including safe distances between various facilities as per applicable rules/acts/laws including PESO guidelines, local byelaws are met. The reference standard shall be ISO 19880(1-8):2020.
- 3.6.1.5 The hydrogen fuelling station complex should have sufficient space, proper design, interior furnishing, proper ventilation, proper lighting, temperature control, dust free atmosphere, fire-fighting facilities, etc.
- 3.6.1.6 Design of RCC and Steel structures shall be carried out as per IS 456 and IS 800 respectively.
- 3.6.1.7 The buildings and allied works shall be designed to meet the requirements of NATIONAL BUILDING CODE, NFPA, IEC, relevant Indian Standards and latest ECBC standards.
- 3.6.1.8 The rainfall data in one hour (in mm) as per meteorological data from IMD shall be considered for the design of the drainage.
- 3.6.1.9 The provisions of Criteria for earthquake resistant design of structures as per IS 1893-1 shall be followed for the design of the foundation, building structure and other facilities.
- 3.6.1.10 The provisions for basic wind speed shall be as per Code of Practice for Design Loads (other than earthquake) for Buildings and Structures IS 875-3.
- 3.6.1.11 Broad layout of office cum switchgear room is enclosed in Annexure-III.
- 3.6.1.12 For corrosion protection, painting is to be applied following the corrosive Category (C) as per ISO 12944-2.
- 3.6.1.13 RCC Structure around the storage cylinders cascade with separation distances (as per CCoE) shall be provided with 4 hours fire resistant rating for structure as per IS:1642.

3.6.2 Building Materials Specifications

- 3.6.2.1 The details of building material are listed below is not exhaustive and indicative only. However, the bidder may propose alternative for approval of owner during detailed engineering.
- 3.6.2.2 Civil Work
 - A. External Walls - Cement plaster, white cement primer, pop's

- etc., Exterior Emulsion Paint (Rain & Dust proof)
- B. Internal/Partition Walls - Acrylic Emulsion
- C. External glass curtain wall unit. - Double glazed unit or triple glazed unit.
- D. External glass window unit. - Double glazed unit or triple glazed unit.
- Aluminum door section and framing. Maximum SHGC (Solar Heat Gain Coefficient) as per super ECBC Standard.
- E. Door
 - i. External and Internal: Door shall be fully insulated with locking system, hinges, hydraulic door closures. Fireproof doors shall be provided as per requirement.
 - ii. Steel Rolling Shutter (Mechanical Gear Operated), Metal rolling shutters and rolling grills as IS: 6248:1979.
 - iii. Collapsible Steel Gates, Clause 10.5 & Fig 10.2 CPWD SPEC Vol:1 (2009)
 - iv. Main Entrance door shall be provided with auto open and close operation
- F. Roof - Provided with Water proofing treatment on roof with fiber glass cloth and water proofing cement compound and screened concrete
- G. External Facade - Size may be changed as per the final detailed drawing.

3.6.2.3 Finishing (Designed based on Super ECBC criteria)

- A. Flooring –
 - i. Heavy duty vitrified ceramic tiles and heavy-duty anti-skid ceramic tiles for toilets.
 - ii. Granite/kota stone for storeroom and steps.
 - iii. Cement concrete flooring with ironite hardener with 200 mm skirting. Electrical insulation coating over the floor based on IEC/ISO standards
 - iv. Acid/Alkali resistance tile flooring. Acid/ Alkali resistant Dado -2100 mm. above, that Acid/Alkali resistant or chlorinated rubber paint.
- B. False ceiling – 15mm thick mineral fiber board with LED light fixtures, Air ducts etc.,
 - i. Battery room - Acid/Alkali resistant or chlorinated rubber paint.
- C. Toilet & Pantry - Oil bound distemper.

Note: The above specification details are based on the preliminary design stage. There can be few changes during detailed architectural and interior design process.

E. DOCUMENTATION

The documents and drawings as listed below are to be submitted by the EPC for the approval of the Owner unless specified otherwise. The list given below is not exhaustive but indicative only.

Three sets of all necessary documentation (hardcopy, English) such as user's manual, operating manual, vendor manuals, product catalogues, wiring diagrams, drawings, termination drawing and interconnecting schematic diagram etc. for the whole system (electrolysers, compressor, storage tubes/vessels, dispenser etc.) besides their soft copies.

1. All civil, mechanical, electrical, instrumentation simulation and field studies, design data and calculations etc., shall be submitted to Owner in hard and soft copies.
2. Relevant drawing, specification, datasheets and other required to fulfil the intent of ensuring operability and the reliability of the complete system covered under this specification are to be supplied to Owner.
3. Hydrogen production curve variations at part load operation.
4. All necessary third-party certificates for all the critical components (electrolysers, compressor, dispenser, high pressure storage tubes/vessels).
5. Hazard and Operability study (HAZOP), QRA, HAC, EMERA, HIRA, SIL, DMP reports
6. Ingress Protection (IP) standard compliance certificate.
7. Report of factory/laboratory calibration certificates of devices/instrument(s).
8. All ownership certificates should be in the name of Owner.
9. As-build drawings of all mechanical, electrical, instrumentations, civil etc.,
10. Layout of Hydrogen Station and office cum switchgear building drawing as per super ECBC standard with all dimensions, simulation model along with input/output simulation report, facilities, testing facilities, cabins/ rooms/ offices, service lines, etc.
11. Design criteria, survey & investigation reports, drawing/documents of the Civil Infrastructure, Super structure and Sub-structure, foundation and underground facilities for approved of Owner/Engineer-In-Charge before the start of works.
12. All architectural drawings required for execution of construction work such as detail floor plans, detail elevations, detail sections and other miscellaneous architectural details such as finish schedule (internal and external), colour schemes (both internal and external), doors and windows, flooring details and pattern, false flooring, false ceiling, sanitary, plumbing, etc.
13. Report for various statutory requirements and their compliance of the facilities and systems etc.
14. As-Built final architectural drawings, considering Super ECBC parameters, Material test certificates.

F. O&M CONTRACT²¹

1. The next day (00.00 hrs) after completion of successful trial operation and PG test for the station will be considered as the start date of O&M contract for the bidder.
2. Scope of the bidder includes the complete O&M of the hydrogen generation, compression, storage, and dispensing system for the period of _____ years. All the spares and consumables required for the O&M of the system is in the scope of the bidder. The bidder directly or through their authorized agencies having experiences with equipment requiring Zone-0/Zone-1 compliance (hazardous area classification) for a period of not less than two years, will provide O&M services.
3. The O&M period may be extended with the mutual consent of owner and the bidder.
4. Performance Bank Guarantee (PBG) for the O&M of the contract shall be ___% of the O&M portion of the contract price. The PBG shall be submitted 30 days before the start of O&M of the contract by the bidder. There would be penalty, for each instance, at the rate of _____% of the O&M portion of the contract price if the below mentioned performance criteria are not met.
 - a. The average availability of the system must always be above 95% annually (24 hrs x 365 days).
 - b. The interruption should not be for more than two days, at a stretch.The system will be considered available only when it meets all the parameters of the specifications, the system is 100% safe and hydrogen is fit for dispensing into the vehicle.

The overall ceiling on penalty shall be _____% of the O&M portion of the contract price.
5. One complete set of tools and tackles (safety and special), portable measuring and monitoring instruments, portable gas leak detectors shall be provided by the agency at the end of O&M period.

²¹ The number given in the chapter are indicative guidance only. Owner shall exercise their discretion for specifying appropriate parameters.



Annexure-I: Water Quality Parameters

Sl. No.	Parameters	unit	Observed Value	Limit (Max.)	Test Methods
1	pH value	
2	Calcium hardness	mg/l as CaCO ₃
3	Magnesium hardness	mg/l as CaCO ₃
4	Sodium / Potassium	mg/l
5	Total cations / Total Anions	meq/l
6	Dissolved silica	mg/l as SiO ₂
7	P-Alkalinity / M-Alkalinity	mg/l as CaCO ₃
8	Chloride / Sulphate / Nitrate	mg/l
9	Total Suspended Solid	mg/l
10	Chemical Oxygen Demand	mg/l
11	Biological Oxygen Demand	mg/l
12	Total Dissolved Phosphates	As p
13	Total Nitrogen	As N mg/l
14	Fecal Coliform	MPN/100 ml

Annexure-II: Basic Electrical Scheme²²

Basic electrical scheme is as indicated below.

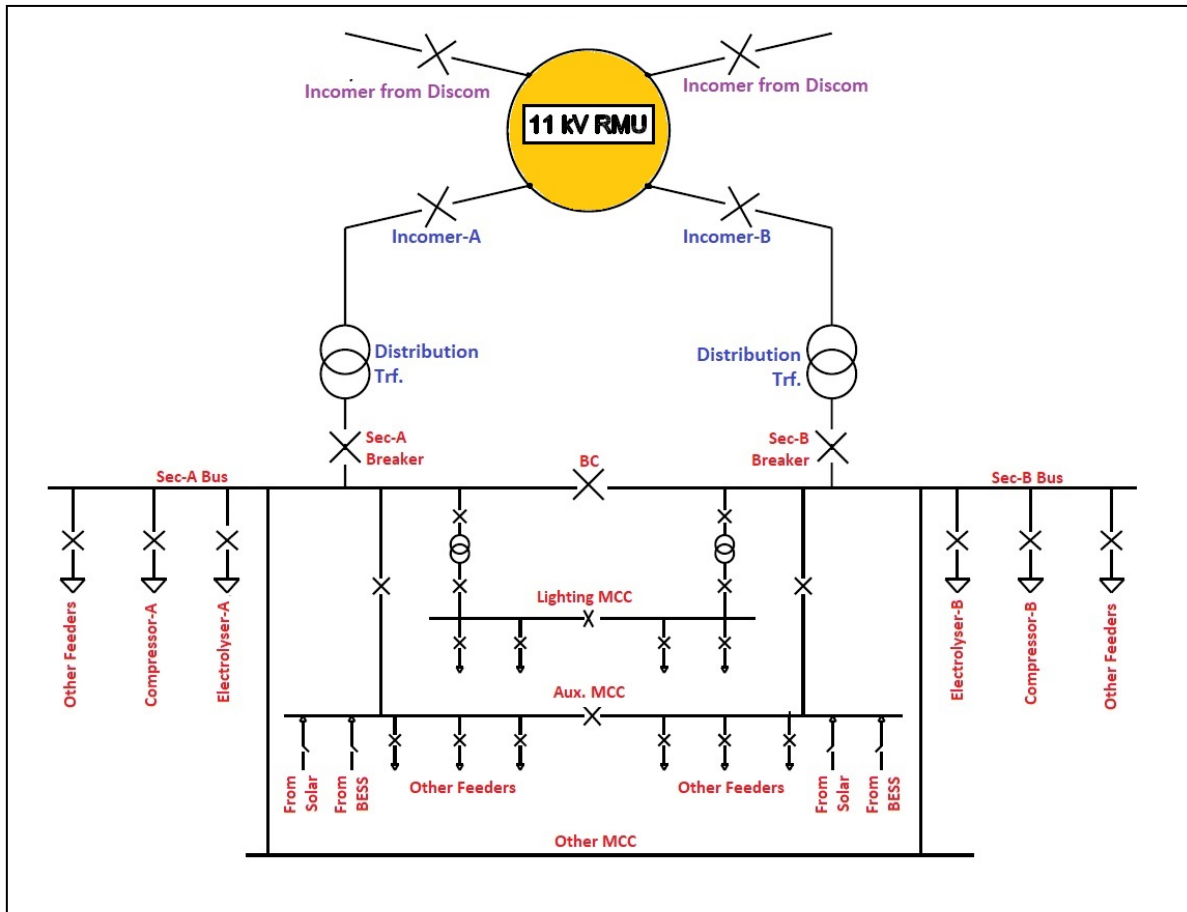

Note: Above electrical scheme is tentative and subject to the availability of two incoming feeders. In-case one incoming feeder is available, bidder shall be responsible to install suitable standalone breaker for all incomer breaker for transformers.

²² Above scheme is only indicative. Owner shall provide the single line diagram of the existing or new network available for the power connectivity. Owner can also propose the electrical scheme required for this project.

Annexure-III: Broad Layout of Office cum Switchgear Room

Broad layout in Office cum Switchgear Room

S. No.	Space Name	Carpet Area* (Sq. m) (tentative)
1	Entrance Lobby & Waiting Area	-----
2	Model & Display Room	-----
3	Common Toilet - He	-----
4	Common Toilet - She	-----
5	HOS Room	-----
6	Conference & VC Room	-----
7	HOS Room - Toilet	-----
8	HOS Room – extra space	-----
9	Pantry	-----
10	Battery Room	-----
11	SCADA Room	-----
12	Control Room	-----
13	Storeroom	-----
14	Switchgear Room	-----
15	Passage Area	-----
16	Security Room	-----
17	Security Toilet	-----
18	Driver Rest Room	-----
19	Driver Toilet	-----
Total Area (Sq. m)		-----

*Varies based on the design and finalized during detailed engineering

Annexure-IV: Building Materials

Details of the building materials

Building material	Detail	Conforming Standard	Remarks
Cement	Ordinary Portland Cement (OPC) Fly ash-based Portland cement	IS 8112:2013 IS 1489:2015 Part 1	Min Grade-43
Coarse and Fine Aggregate		IS 383 :2016	
Reinforcement steel	TMT bar min. grade Fe 500 Mild steel, medium tensile steel bars and hard drawn steel wire Welded wire fabric	IS 1786:2008 Grade-1 of IS 432:1982 Part 1 IS 1566 :1982	
Concrete for structures	Min. M25	IS 456:2000	
Structural steel	All angle, channel, plates etc. min. Yield strength 250 Mpa Hollow tube Hollow sections	IS 2062:2011 IS 1161:2014 IS 4923:2017	Min. base metal thickness 2 mm, Minimum coating of 100 microns
Wood		IS 3614:1992	
Fly Ash	Fly Ash Bricks Paver blocks / Interlocking tiles		

Annexure-V: Topographical survey and soil/geotechnical investigation

Topographical survey and soil/geotechnical investigation results of the project location



A. Human Machine Interface

HMI software shall include:

1. Graphic (HMI) displays all process areas, showing equipment status (ready, not ready or running) and analog values for critical process variables.
2. There shall be multiple levels (types) of process graphics:
 - a. Level 1 graphics are used for navigation between offsite locations, display KPIs (Key Performance Indicators), alarm summary, trends, and run reports.
 - b. Level 2 graphics will mirror the PFDs (Process Flow Diagrams) for each offsite location for normal control operations.
 - c. Level 3 graphics will mirror the P&IDs (Piping and Instrumentation Diagrams) for each offsite location for detailed control operations.
 - d. Level 4 graphics will be provided as necessary for equipment specific integration screens and auxiliary information.
3. Alarm display and logs, showing the alarm tag number, title, date and time.
4. Trend displays with flexible time and process variable axes for any analog process variable.
5. Loop displays showing PID controller settings and trending of process variable, setpoint and output.
6. Password controlled multiple user access levels like Operator, Supervisor and Engineer.
7. Graphic panels shall be created to replicate process and equipment using ISA standard and/or custom build symbol library. The system shall support 3D representations with rich color combinations for static and dynamic indications.
8. Data refresh rate in graphics for hardwired IOs shall be 1-2 sec and through communication shall be 3-5 sec.
9. Reports shall support standard and custom developed allowing multiple report formats (shift-wise, daily...), scheduled and adhoc reporting.
10. Number of reports and graphics shall be based on operational needs and shall not limited by the number of licenses
11. Ability to configure and operate sequence and control functions in
 - a. Auto and Manual modes
 - b. Start-up Bypass and Overrides for interlocks
 - c. Maintenance Modes
12. Ability to synchronize time
13. Alerts on critical alarms and/or data shall be send to key operation/maintenance personal over SMS and/or emails
14. Diagnostic details from various system components shall be presented as alarms in the system

B. SCADA Server

The SCADA Server (SCD) shall be PC based running SCADA/HMI software on a Windows Server 2019 or latest operating system. This server will collect raw data from the ICS Controller, Safety System, Fire and Gas System, and third-party PLCs to make it available to operator works stations. The SCADA servers shall be configurable as redundant pairs. The following hardware requirements apply, else virtual hardware should be assigned with similar capability.

Minimum specification for Server shall be:

- Intel I7 processor or better
- 16 GB RAM, Min. 1TB SSDs with Raid 3
- Dedicated Graphics Card, Network Card
- Single 32” Monitor, Keyboard and Mouse

C. Operator Workstation

Operator Workstation (OWS) shall be PC based running SCADA/HMI software on Windows 10 or latest operating system. Operator shall use this as a single window for the control and monitoring of the entire process and facility related input/outputs. Its shall comply with ISO 9241-5, 9241-302 and 9241-303 and ISO 11064.

Minimum specification for OWS shall be:

- Intel I7 processor or better
- 16 GB RAM, Min. 1TB SSDs
- Dedicated Graphics Card, Network Card
- Single 32” Monitor, Keyboard and Mouse.

D. Engineering Workstation

Engineering Workstation (EWS) shall be PC based running SCADA/Programming software on Windows 10 or latest operating system. A single software platform that allows configuration of controllers and SCADA HMI is preferred. EWS shall include OWS software also.

Minimum specification for EWS shall be:

- Intel I7 processor or better
- 16 GB RAM, Min. 1TB SSDs with Raid 3
- Dedicated Graphics Card, Network Card
- Single 32” Monitor, Keyboard and Mouse.

EWS shall be based on IEC-61131-3 for programming of controllers and HMI.

E. ICS - Controller

Features and requirements of CPU stated below shall be met.

- a. Be of robust design using reliable components with high availability. Be compact, stand-alone din rail mountable.

- b. Not include moving parts whose failure results in failure or degradation of system performance. All the performances committed shall not deteriorate in the entire range of operating temperature.
- c. Support redundancy for hot-standby operations
- d. Possess redundant equalizing ports (no single point failure) to exchange diagnostic/failure details to perform switchover. Switch overtime shall be of the order of 300 mSec.
- e. Support multiple scan times for digital processing (50 msec), critical analogue controls (500 msec) and 1 second for the rest.
- f. Capable of solving application logic, storing the application program and having an OLED status display.
- g. Be based on intel or compatible microprocessor operating at speeds no less than 1GHz as the main processing element, memory mounted on the board. A min of 32Mb of retentive user memory shall be on board for user configurable application data storage and documentation storage.
- h. Possess dedicated ethernet ports with speeds of 10/100/1000mbps for IO communication.
- i. Be cyber secure with a certification like Achilles 2 or equivalent. Additionally, it shall include provisions around password protection, encrypted communications, encrypted firmware updates. All devices, testing and processes shall be adhered to IEC 62443.
- j. Be certified CE, UL, ATEX, C1D2, ATEX Zone 2, ABS, BV, DNV, GL for operating in harsh environment.
- k. Support Modbus TCP/IP, HART Passthrough, Profinet, OPC UA, DNP3 protocols for devices and/or packaged system integration
- l. The CPU should have the capability to interface to the cloud and send data, if required.

F. Networking

Firewalls shall be used as a method of protection between the ICS, any third-party equipment, and the cloud/internet if applicable. The firewalls used should provide deep packet inspection of any industrial protocols used by third-party equipment. These firewalls shall operate in a redundant configuration.

Industrial Ethernet switches shall be used in the ICS cabinets that meet the environmental requirements of the site. These switches shall operate in a redundant configuration. The switches shall be L2 Managed type that supports

- a. 24 VDC power input
- b. 10/100 mbps copper port
- c. 1000 mbps fibre port
- d. The number and type of ports shall be decided based on the number of connections to the devices.
- e. Industrial grade suitable for operating at 70 Deg C temperature

One router per site shall be installed in the ICS cabinets that meet the environmental requirements of the site. The router shall facilitate a wired WAN interface to connect to the local ISP's (internet service provider) modem and support a cellular interface as a backup. An outdoor antenna will be required for a strong cellular connection. These types of routers do not function as a redundant pair.

All networking devices, PLC system, service shall be in synchronization with 100% redundant external clock i.e. GPS

G. ICS – Input / Output

ICS shall include dedicated remote IO racks installed in multiple locations and connected to the centralized CPUs. IO racks shall include power supplies, communication to CPU and various types of IO cards.

IO Cards in general possess/support the following features.

- a. LED indicators for Power, Healthiness of card and status of digital signals
- b. Galvanic isolation between system and field to 1500 VAC
- c. Noise filters
- d. Hot replacement i.e., removal and insertion with power on
- e. Reverse polarity protection
- f. Diagnostics to detect failures and send status updates to the controller/HMI.

There shall be a maximum of 1 model number used for each of the following I/O types in the ICS to minimize the amount of spare I/O cards the customer will need to keep on hand:

- a. Discrete Inputs, Discrete Outputs
- b. Analog (4-20 mA) Inputs and outputs
- c. RTD/TC Inputs, Pulse Inputs

The maximum number of channels allowed for AIO cards is 16 and DIO cards is 32.

H. Data Historian

SCADA server shall be capable of storing raw, computed and aggregated data as defined in a structured database for extended periods of time (one year). Data from the historian shall be used for reporting, performing analytics and shared with Owner systems. Data communication to external systems shall be using OPC protocol. Any other protocol shall be with prior approval from Owner.

I. Web Clients

Using Web Clients, the system shall facilitate remote access to the data and/or graphical/report data for the purpose of monitoring. Mobile phones, tablets or PC connected through internet from a far location shall be allowed to access with proper user authentication. Also, it shall be able to use remote access in parallel to the local access in the control center.

J. ICS – Redundancy Requirements

Listed below are the guidelines identified for the redundancy requirements of this plant.

- CPU, IO communication and power supplies shall be redundant

- Critical IO(s) and communication links shall be redundant.
- OWS shall be minimum two in numbers: 1 x OWS and 1 x OWS cum EWS.
- EWS shall be minimum one in number: 1 x EWS (excl of above)

Depending on the process operational needs additional OWS may be requested.

K. ICS – Spare Philosophy

Listed below are the minimum spare requirements.

- a. IO cards shall include 10% of spare channels and shall be distributed evenly in multiple cards.
- b. IO racks shall include 10% slots for installation of additional cards.
- c. Power supplies shall have 20% excess capacity on top of what is required with all channels + installed spares.
- d. Cabinets shall have 20% spare space to accommodate the additional installed spares/space.
- e. Terminals and cable raceways shall have 20% spares on top of what is required with all channels + installed spares.
- f. Accessories such as MCBs, signal conditioners, barriers and surge protectors – as applicable shall be per installed spares channel requirements.
- g. Network ports shall include 20% spare ports.
- h. Network loading shall not be more than 40% during normal operations.
- i. CPU shall have an additional 25% capacity for future additions.
- j. Licenses considered shall be on the based-on resources required for given IO with installed spares plus 25% for future expansion.

L. ICS – Single Window

The ICS shall be the single unified platform for monitoring and control needs of the entire plant including process, utilities and facilities.

- To the extent possible, all IO(s) from process and package equipment shall be wired to the ICS and controls implemented in it. Consider usage of package PLC(s) only for impossible cases with approval from the Owner.
- Provide control and monitoring details for the ICSV to develop standardized operation and control philosophy. Key documents that ICSV need from bidder or OEM, or its supplier are.
 - P&ID, IO list and Summary with alarm limits and priorities
 - C&E matrix, Sequence, Control narratives
 - Interlocks with bypass and overrides, Cable schedule
- Entire control system shall be ordered and executed through a single entity of ICSV to ensure consistency in terms of hardware components, assembly and integration, software design with same look and feel.

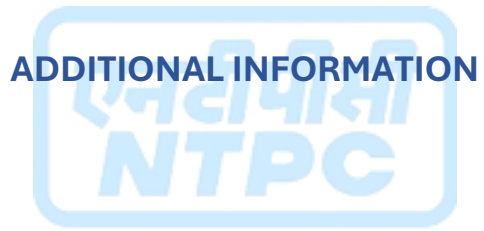

Additional Information-I: List of Standards

The below list of standards to be followed for design, erection/installation/construction, commissioning & testing, O&M of equipment, building & layout etc., for entire project by the bidder. List of standards which are detailed below, and it is not limited, latest and other standards for Hydrogen Application are also applicable.

S. No.	Standards	Description
1	ISO 14687: 2019	Hydrogen fuel quality — Product specification.
2	ISO 22734: 2019	Hydrogen Generators using water electrolysis – Industrial, Commercial & Residential Applications.
3	ISO 19880: 2020 Part 1 - 8	Gaseous Hydrogen Fuelling Station.
4	ISO/TR 15916:2015	Basic considerations for the safety of hydrogen systems
5	ISO 12944-2:2017	Paints and varnishes — Corrosion protection of steel structures by protective paint systems
6	NFPA 2	Hydrogen Technologies Code.
7	NFPA 10	Standard for Portable Fire Extinguishers.
8	NFPA 14	Standard for the installation of Standpipe and Hose System
9	NFPA 20	Standard for Installation of Stationary Pumps for Fire Protection
10	NFPA 22	Standard for Water Tanks for Private Fire Protection
11	NFPA 24	Standard for the Installation of Private Fire Service Water Mains
12	NFPA 70	National Electrical Code
13	NFPA 2001	Standard on Clean Agent Fire Extinguishing Systems.
14	SAE J2601-02:2014	Fueling Protocols for Light Duty Gaseous Hydrogen Surface Vehicles
15	SAE J 2799:2019	Hydrogen Surface Vehicle to Station Communications Hardware and Software
16	SAE J2601/3: 2014	Fuelling Protocols for Light Duty Gaseous Hydrogen Surface Vehicles
17	SAE J 2719: 2020	Hydrogen Fuel Quality for Fuel Cell Vehicles
18	AIS 157:2020	Safety and Procedural Requirements for Type-Approval of Compressed Gaseous Hydrogen Fuel Cell Vehicles.
19	ANSI / ASME A13.1, (or) ASME A13.1: 2020	Scheme for the Identification of Piping Systems.
20	ASTM G93/G93M-19	Standard Guide for Cleanliness Levels and Cleaning Methods for Materials and Equipment Used in Oxygen-Enriched Environments.
21	IEC 60079	Electrical apparatus for explosive gas atmospheres
22	ASME B31.12:2019	Hydrogen Piping and Pipelines
23	ASME B31.1:2022	Power Piping
24	API-RP	American Petroleum Institute - Pipeline Recommended Practices (RP)

25	EC-79	European Regulations
26	ATEX & IECEx	EU directives - minimum safety requirements for workplaces and equipment used in explosive atmospheres. IECEx – The IEC System for Certification to Standards relating to Equipment for use in Explosive Atmospheres
27	BIS IS 3792: 1978(R2004)	Guide for heat insulation of non-industrial buildings.
28	IS:875 (Part 1) - 1987	Code of Practice for Design Loads (Other than Earthquake) for Buildings and Structures (Part 1 – Dead Loads)
29	IS:875 (Part 2) - 1987	Code of Practice for Design Loads (Other than Earthquake) for Buildings and Structures (Part 2 – Imposed Loads)
30	IS:875 (Part 3) - 2015	Code of Practice for Design Loads (Other than Earthquake) for Buildings and Structures (Part 3 – Wind Loads)
31	IS:875(Part 5)– 1987	Code of Practice for Design Loads (Other than Earthquake) for Buildings and Structures (Part 5 – Special loads & load combination)
32	IS:1893(Part 1) -	Criteria for Earthquake Resistant Design of Structures (Part 1 –
33	IS:1893(Part 2) - 2014	Criteria for Earthquake Resistant Design of Structures (Part 2 – General Provisions for Liquid retaining structures)
34	IS:1893(Part 3)-	Criteria for Earthquake Resistant Design of Structures (Part 3 –
35	IS:1893(Part 4) - 2015	Criteria for Earthquake Resistant Design of Structures (Part 4 – Industrial Structures including Stack-Like Structures)
36	IS:800 - 2007	Code of Practice for General Construction in Steel
37	IS:808 - 1989	Dimensions for hot rolled steel beam, column, channel and angle
38	IS:813–2018	Scheme of Symbols for Welding.
39	IS:456 - 2000	Plain and Reinforced Concrete – Code of Practice
40	IS:13920 - 2016	Code of practice for ductile detailing of reinforced concrete structures subjected to seismic forces
41	IS:1786 - 2008	Specification for high strength deformed steel bars and wires for concrete reinforcement
42	IRC:6 – 2014	Standard Specifications and Code of Practice for Road Bridges, Section II – Loads and Stresses (Fourth Revision)
43	IRC:21 – 2000	Standard Specifications and Code of Practice for Road Bridges, Section III – Cement Concrete (Plain and Reinforced) (Third Revision)
44	IRC:58 – 2015	Guidelines for the Design of Plain Jointed Rigid Pavements for
45	IRC:15 – 2011	Standard specifications and code of practice for construction of
46	IS:3370 (Part 1) –	Concrete structures for storage of liquids – General requirements
47	IS:3370 (Part 2) –	Concrete structures for storage of liquids – Reinforced concrete
48	IS:3370(Part 4)–	Code of Practice for Concrete Structures for Storage of Liquids; Part
49	IS:1904–1986	Code of Practice for Design and Construction of Foundations in Soils
50	IS:1905 – 1987	Code of Practice for Structural use of Un-reinforced Masonry
51	IS:11089 – 1984	Code of practice for design and construction of ring foundations
52	IS:6509 – 1985	Code of practice for installation of joints in concrete pavements
53	IS:2062 -2011	Code of practice for Hot rolled medium and high tensile structural
54	IS:1080–1985	Code of Practice for Design and Construction of Shallow
55	IS:2950(Part 1)–	Code of Practice for Design and Construction of Raft Foundations
56	IS:4326–1993	Code of Practice for Earthquake Resistant Design and Construction
57	IS:11089–1984	Code of Practice for Design and Construction of Ring Foundation;
58	IS 3646:1992	Code of practice for interior illumination

59	PESO	Gas cylinder Rule, 2016
60	PESO	Static & Mobile Pressure Vessel (Unfired) Rules, 2015
61	IBR- Regulation 374	Indian Boilers Regulations - 1950, Regulations
62	IS 7861:2009	Code of practice for extreme weather concreting
63	IS 6248:1979	Metal Rolling Shutters and Rolling Grills



Additional Information-II: Trial operation and Performance Guarantee (PG) test

1. Trial operation shall be considered to be completed if the system runs trouble-free for 2*24 hours consecutively at full load operation. This includes operation of hydrogen generation, compression, storage, dispensing hydrogen into FCEVs and/or venting into atmosphere.
2. PG Test shall be conducted immediately after the completion of trial operation.
3. PG tests after completion of trial operation, bidder shall arrange all materials, equipment's, including supply and calibration of PG Test instruments, T&P, manpower etc., which are required to carry out PG Test by the bidder, at free of cost.
4. Procedure shall cover the PG tests to be conducted at site for the entire system/subsystems and individual equipment (as required) covered in Contract. The PG test requirements and procedure of PG test to be followed are detailed below.

A. Requirements

Part-I

1. Hydrogen production capacity to be demonstrated as per Table 2 (Sl. no.3)
2. Hydrogen (purity, moisture content/Dew point, Oxygen content) parameter should be demonstrated at inlet of low-pressure Storage vessels per Table 2 (Sl.no.4).
3. Continuous hydrogen production for at least six hours of operation with one drier in service for a capacity at 20% of Table-2 (Sl. no.3) with hydrogen purity as per Table 2 (Sl.no.4).

Part-II

4. Fueling parameters including auto cut-off and cut-in pressures, max. flow rate as per SAE standards etc., for hydrogen fueling to FCEVs at the and match with Table 5 (Sl.no.3).
5. Operation of priority panel during trouble free filling of at least two FCEVs in succession as per Table 5 (Sl. no.1&2)

Part-III

6. Total power consumption of the station, in a 24 hours of PG test, to be less or up to _____ kWhr/day. The test shall commence with min. 10% charge of BESS, hydrogen generation from zero to rated capacity, compression and storage at rated pressure and fueling ___ nos of FCEV buses from residual capacity of FCEV buses and/or venting into atmosphere, with rated power consumption of office buildings (including HVAC, switchgears, control, and equipment rooms etc.,).
7. Control, annunciation panel and safety devices shall be checked for all the functions of interlock and protection for local and remote operation.

B. Procedure to be followed

1. Hydrogen production capacity will be measured using "On-Line Mass Flow Meter"
2. Hydrogen parameters shall be taken from gas chromatograph are to be used for purity, moisture, O2 content in traces.

3. The power consumption will be measured at the incomer of MCC / Electrical Panel, by kWh Meter.
4. All instruments should be calibrated from Govt. approved laboratory / NABL and the same should be submitted to Owner. The calibrated instrument should be sealed and opened in front of the Owner representative assigned for PG test. The procedure adapted for carrying out the tests should follow relevant Internationally accepted standards.
5. The protection and interlock checks will be done through simulation or by actual test wherever possible. During the protection and interlock checks the station capacity/ output tests will not be performed as tests are performed individually.
6. Reading of 30 minutes interval of various parameters shall be taken for test duration. The test shall start after a period as per OEM guidelines when the temperature and pressure of the various equipment stabilize.
7. A joint protocol shall be signed between owner and bidder as per approved procedure by Owner.



1. Liquidated Damage (LD)

1.1 Liquidated Damage (LD) for deviation in rated hydrogen delivery output (measured at the inlet of low-pressure storage vessel) per day basis shall be computed as per following formula:

a) Performance Shortfall = (Diff. of tested and guaranteed capacity)/Guaranteed capacity

b) Liquidated damage = (Contract Value) x (Performance Shortfall)

Bidder's liability to pay Liquidated Damages (LD) for failure to attain the performance guarantee shall not exceed five percent (5%) of the Contract Price.

1.2 In case it is found that the equipment/system has failed to meet the guarantees, the Bidder shall carry out all necessary modifications and/or replacements to make the equipment/system comply with the guaranteed requirements at no extra cost to the Owner and re-conduct the PG test(s) with Owner's consent.

1.3 There shall be no incentive/reward in case of positive performance deviation.

2. Warranty Clause

Electrolyser module shall have minimum warranty of five (5) years from date of commissioning. Warranty of all other equipment shall necessarily be covered within three (3) years period from the date of commissioning and the bidder shall be solely responsible for the same.

3. Quality Assurance

The bidder must submit the manufacturing and field quality plan (QP) indicating the practice and procedure along with relevant supporting documents for Owner approval, on award of contract.

4. Training

Arranging training with regards to O&M, safety and first aid for up to ___ persons (required to be completed one months before system is commissioned) will also be in the scope of the bidder.

5. BID Evaluation Criteria

5.1 The bid shall be evaluated based on the quoted price for total project execution i.e., Capex for the project (supply, installation, commissioning with PG test and trial operation requirements) and the O&M cost for the _____ years period. The bidder with lowest quoted price (₹) will be awarded.

5.2 In case of more than one bid have the same quoted price, the bidder declaring higher efficiency (input kwh/kg of hydrogen) of the Hydrogen fuelling station shall



be given preference and be considered for award. The efficiency of the station will be determined by calculating the total power required for the hydrogen station (H₂ generation, compression, storage, dispensing) to provide the required amount of Hydrogen in a day.



A. Sub Qualifying requirements**1. Water Electrolyser Supplier (QR for sub-vendor)**

The sub-vendor should have manufactured or got manufactured a bipolar type of water electrolyser of minimum rated generation capacity of ____kg/hr of hydrogen at single location, within the _____ years period prior to the date of techno-commercial bid opening. The above electrolyser should have been either successfully commissioned at customer's premises or tested for performance at OEM's works.

2. Hydrogen Compressor supplier (QR for sub-vendor)

The sub-vendor should have manufactured or got manufactured a hydrogen compressor of minimum rated capacity of ____kg/hr and minimum discharge pressure rating of _____ bar, within the _____ years period prior to the date of techno-commercial bid opening. The above compressor should have been in successful operation for a period of at least _____ months.

3. Gaseous hydrogen dispenser supplier (QR for sub-vendor)

The sub-vendor should have manufactured OR got manufactured a gaseous hydrogen dispenser for FCEVs, within the _____ years period prior to the date of techno-commercial bid opening. The above dispenser should have been either successfully commissioned at customer's premises or tested for performance at OEM's works.

B. Proven-ness note

If the bidder himself has not done the design, engineering, erection (or supervised erection) and commissioning (or supervised commissioning) of electrolyser with hydrogen generation station of minimum rated generation capacity of ____kg/hr, the bidder shall engage an Agency(ies) with requisite experience as given below:

The agency should have done design, engineering, erection (or supervised erection) and commissioning (or supervised commissioning) of Hydrogen generation station of rated generation capacity of ____kg/hr or higher, within the preceding _____ years prior to the date of techno-commercial bid-opening. The aforesaid hydrogen generation station shall comprise electrolyser, compressor, and storage & associated systems.

D. Defect liability period

Defect Liability period is _____ years from the date of commissioning of the station.

Additional Information-V: Layout of the Project

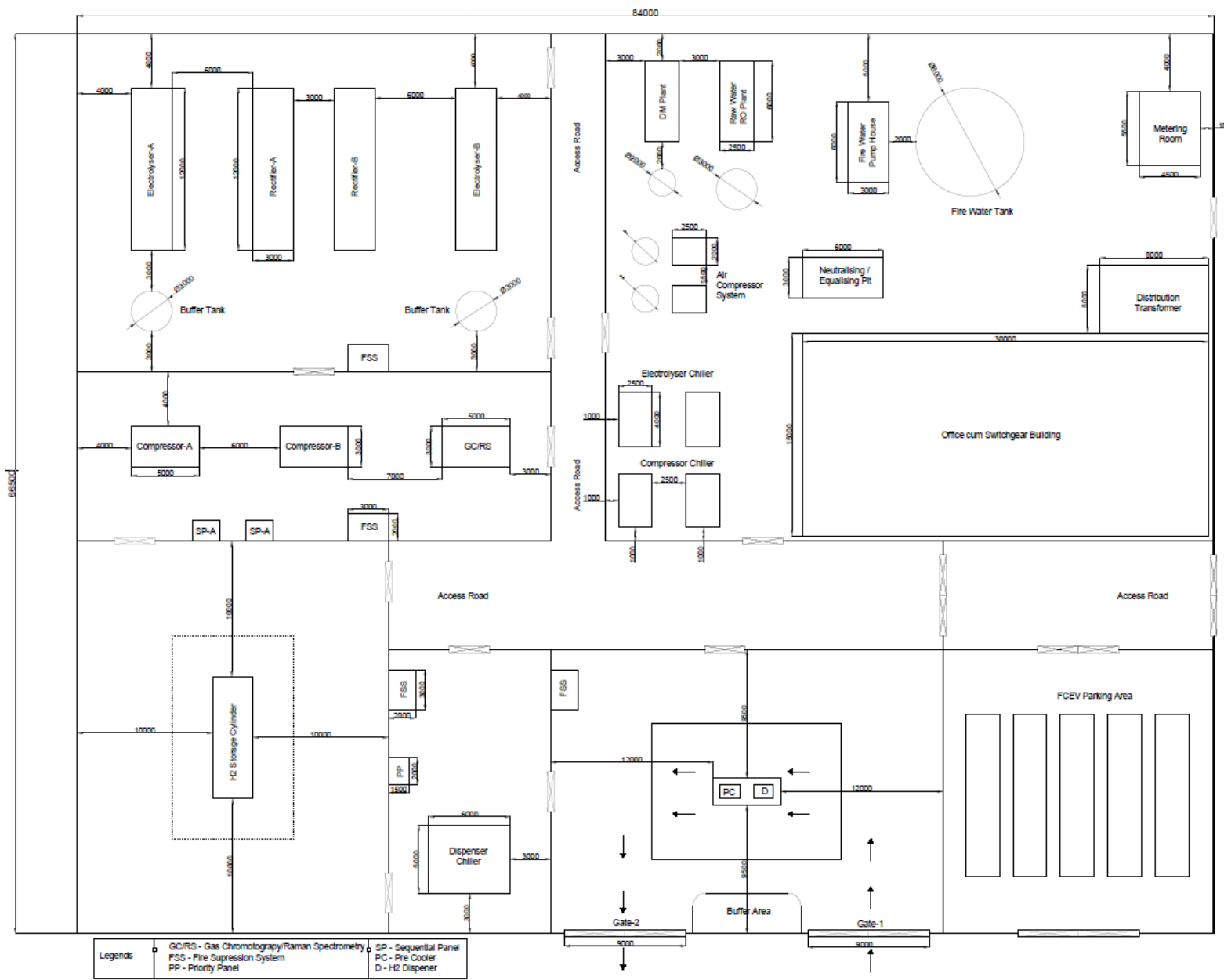

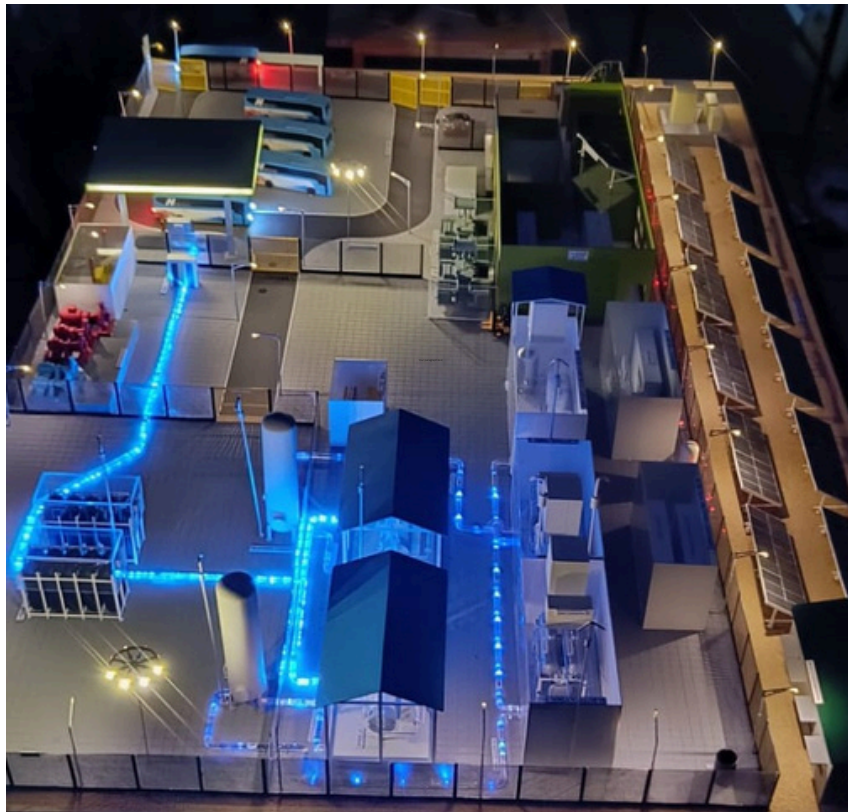

3D Model of NTPC Green Hydrogen Mobility Project, Leh



एन टी पी सी लिमिटेड
(भारत सरकार का उपक्रम)
NTPC LIMITED
(A GOVT. OF INDIA ENTERPRISE)

For suggestions or feedback on enhancing this report, please contact.

Lakshmanan D, Senior Manager, Hydrogen Energy
dlakshmanan@ntpc.co.in

